

STOCK DE SEGURIDAD

$$\text{CTE}_i = b \cdot q + \frac{1}{2} \cdot q \cdot c_1 \cdot t + k + S_P \cdot c_1 \cdot t$$

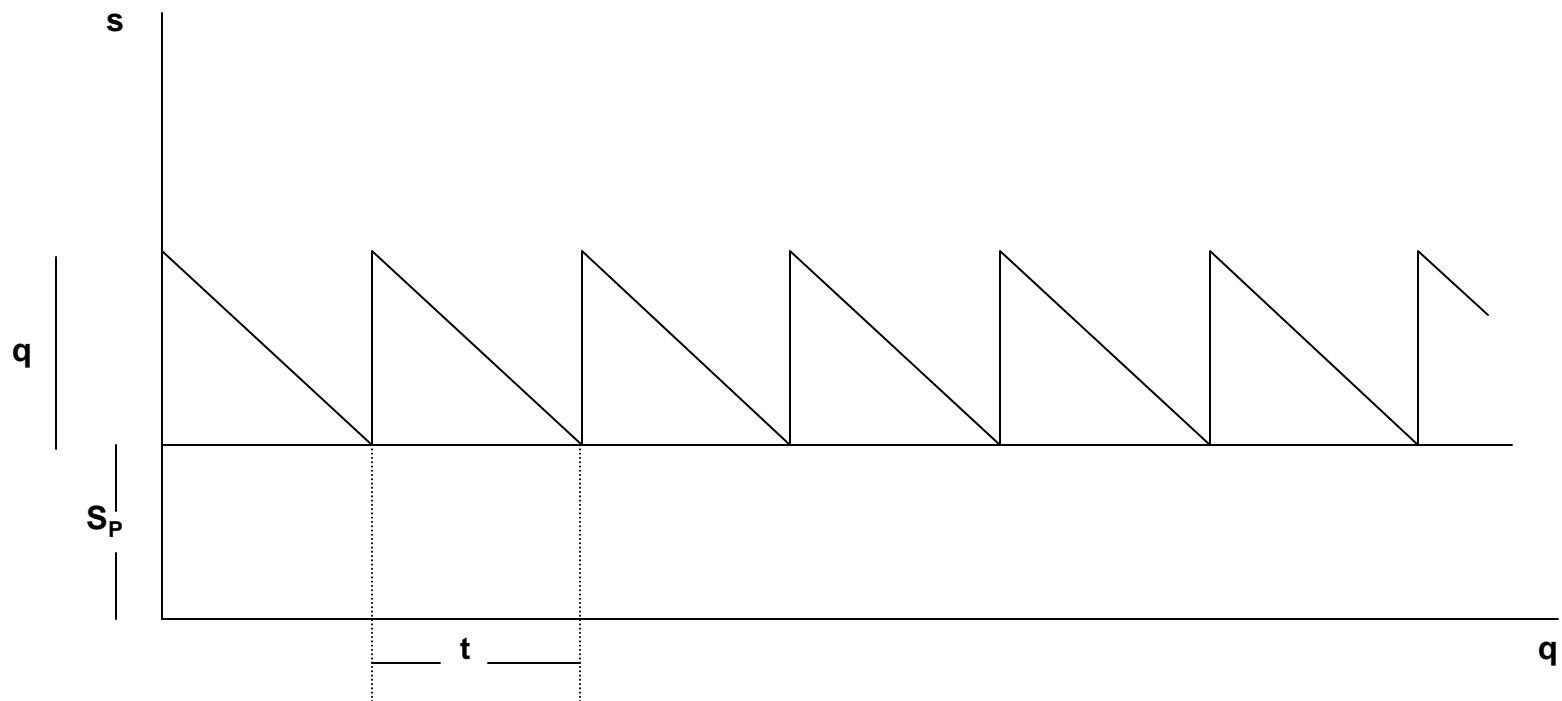

$$\text{CTE}_i = b \cdot q + \frac{1}{2} \cdot q \cdot c_1 \cdot t + k + S_P \cdot c_1 \cdot t$$

$$n = \frac{D}{q} = \frac{T}{t}$$

$$\text{CTE} = b \cdot D + \frac{1}{2} \cdot q \cdot c_1 \cdot T + k \cdot \frac{D}{q} + S_P \cdot c_1 \cdot T$$

$$q_o = \sqrt{\frac{2 \cdot k \cdot D}{T \cdot c_1}}$$

$$\text{CTE}_o = b \cdot D + \sqrt{2 \cdot k \cdot D \cdot T \cdot c_1} + S_P \cdot c_1 \cdot T$$

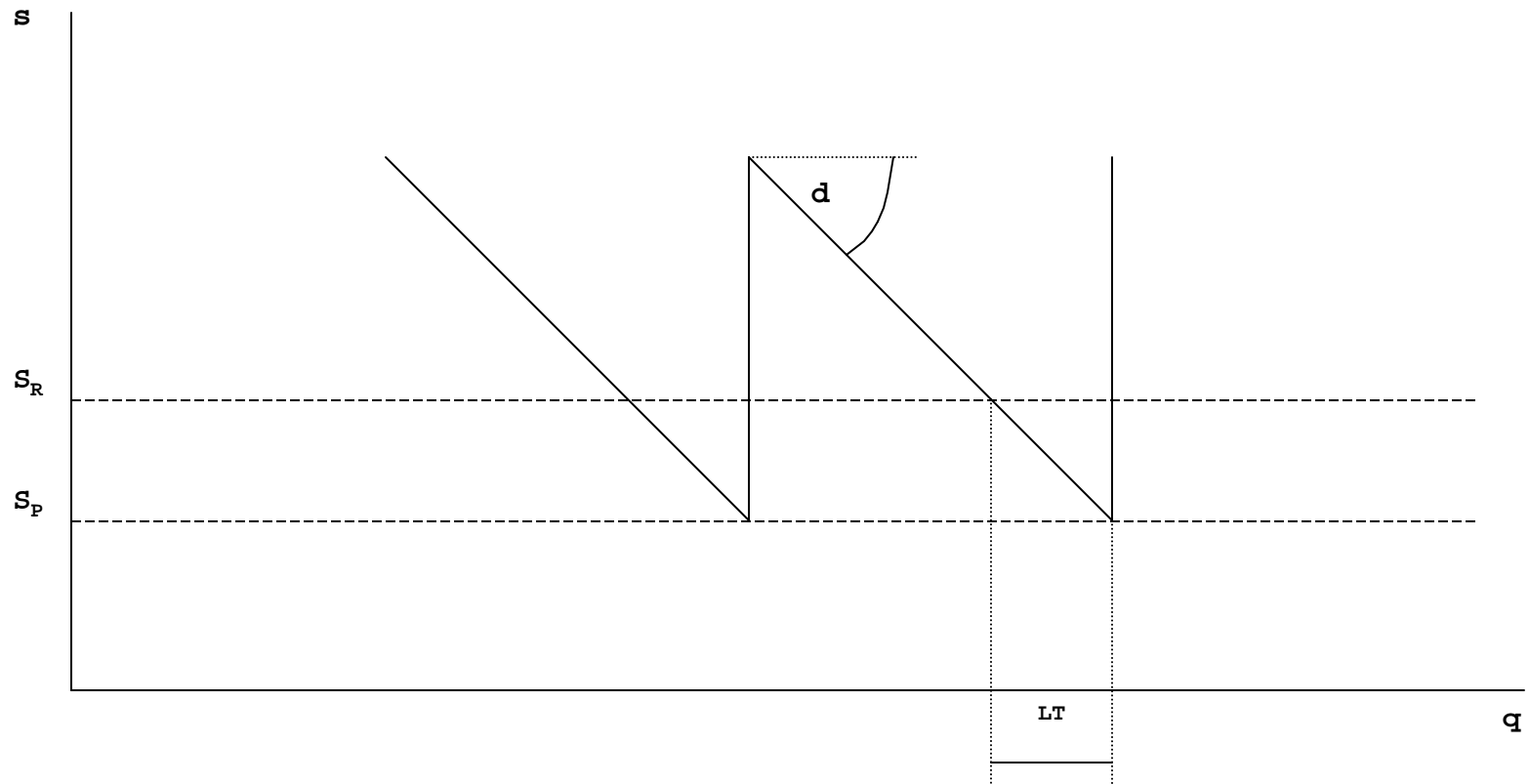

$$S_R = LT \cdot d + S_P$$

AGOTAMIENTO ADMITIDO

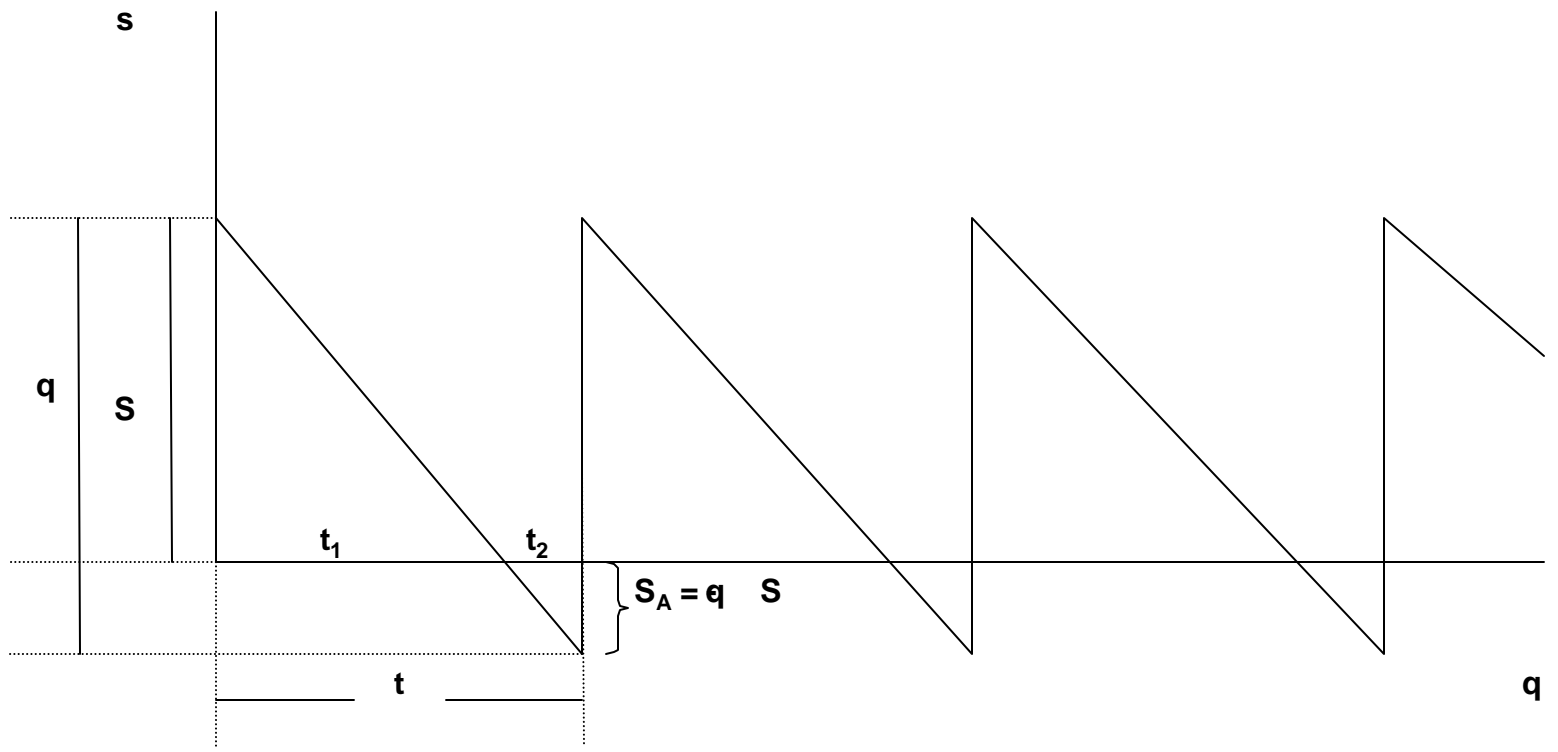

$$\text{CTE}_i = b \cdot q + \frac{1}{2} \cdot S \cdot c_1 \cdot t_1 + \frac{1}{2} \cdot (q - S) \cdot c_2 \cdot t_2 + k$$

$$\frac{S}{q} = \frac{t_1}{t} \quad t_1 = \frac{S \cdot t}{q}$$

$$\frac{(q - S)}{q} = \frac{t_2}{t} \quad t_2 = \frac{(q - S) \cdot t}{q}$$

$$\text{CTE}_i = b \cdot q + \frac{1}{2} \cdot S^2 \cdot c_1 \cdot \frac{t}{q} + \frac{1}{2} \cdot (q - S)^2 \cdot c_2 \cdot \frac{t}{q} + k$$

$$n = \frac{D}{q} = \frac{T}{t}$$

$$\text{CTE} = b \cdot D + \frac{1}{2} \cdot \frac{S^2}{q} \cdot c_1 \cdot T + \frac{1}{2} \cdot \frac{(q - S)^2}{q} \cdot c_2 \cdot T + k \cdot \frac{D}{q}$$

$$q_o = \sqrt{\frac{2 \cdot k \cdot D}{T \cdot c_1}} \cdot \sqrt{\frac{c_1 + c_2}{c_2}}$$

$$S_o = \sqrt{\frac{2 \cdot k \cdot D}{T \cdot c_1}} \cdot \sqrt{\frac{c_2}{c_1 + c_2}}$$

$$\text{CTE}_o = b \cdot D + \sqrt{2 \cdot k \cdot D \cdot T \cdot c_1} \cdot \sqrt{\frac{c_2}{c_1 + c_2}}$$

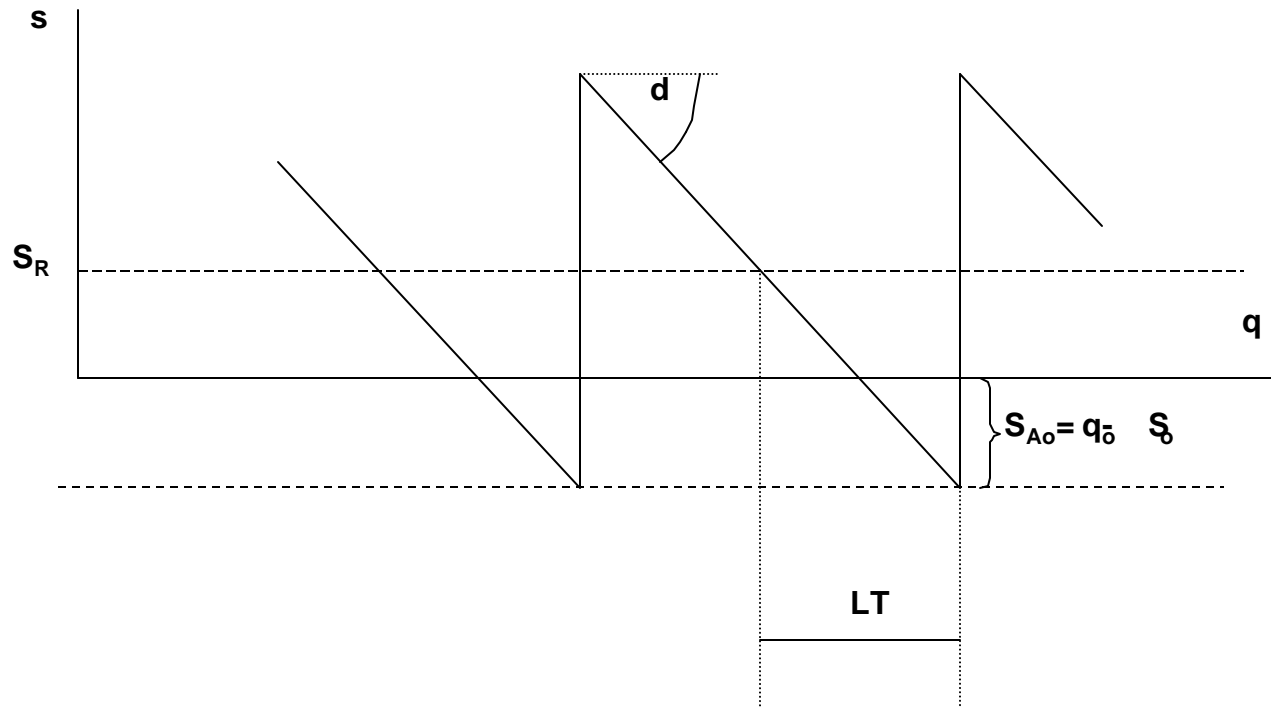

$$S_R = LT \cdot d - S_{A_0}$$

REAPROVISIONAMIENTO
NO INSTANTÁNEO

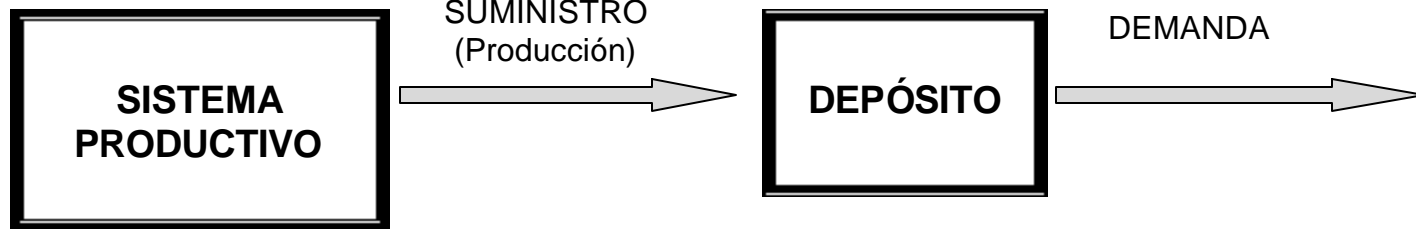

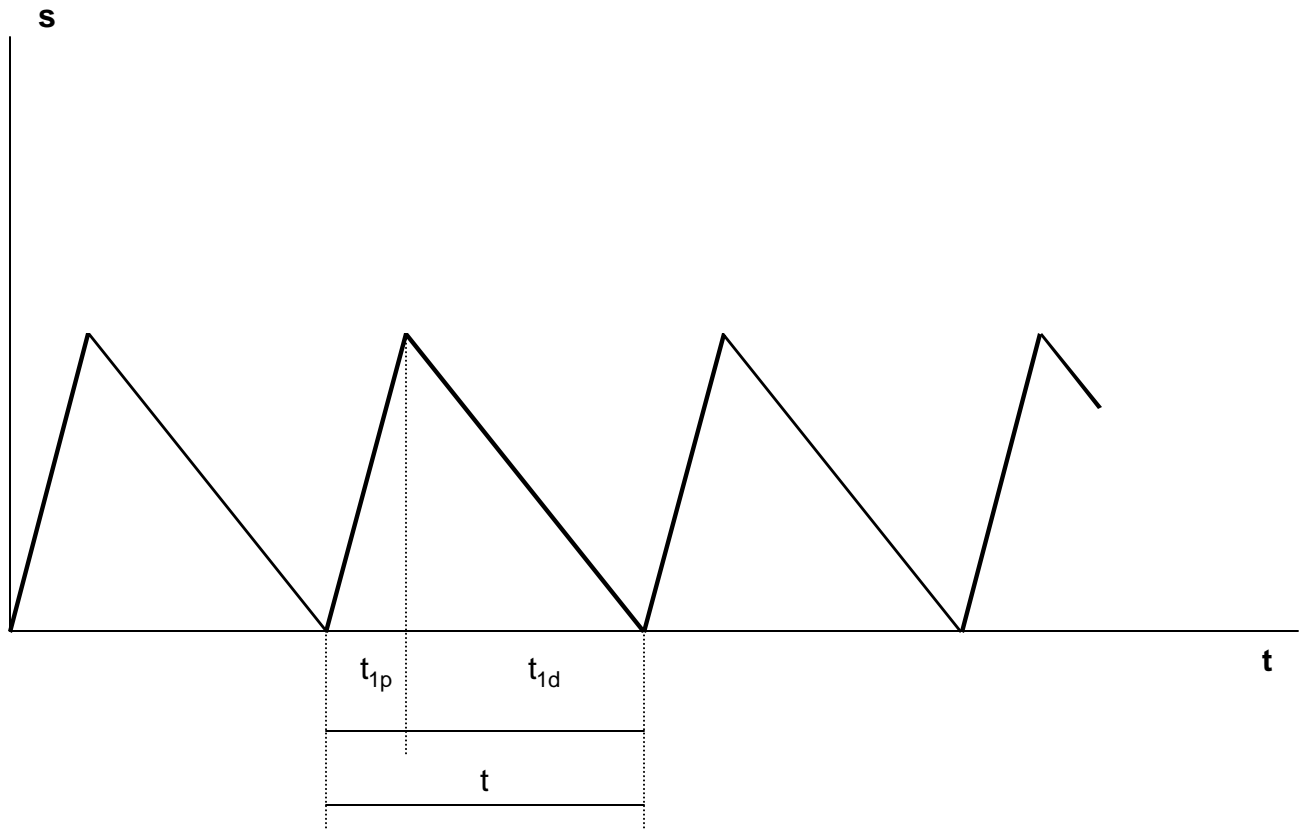

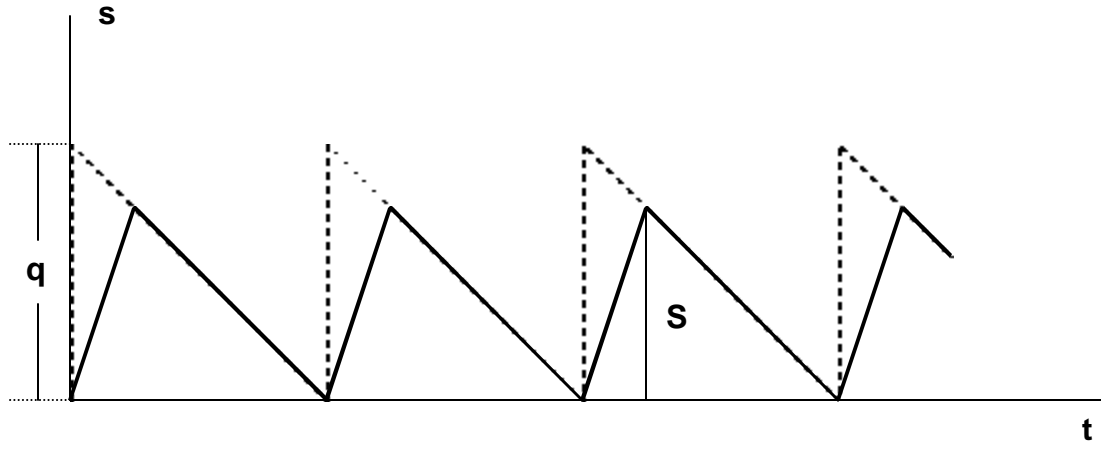

$$\text{CTE}_i = b \cdot q + \frac{1}{2} \cdot S \cdot c_1 \cdot t + k$$

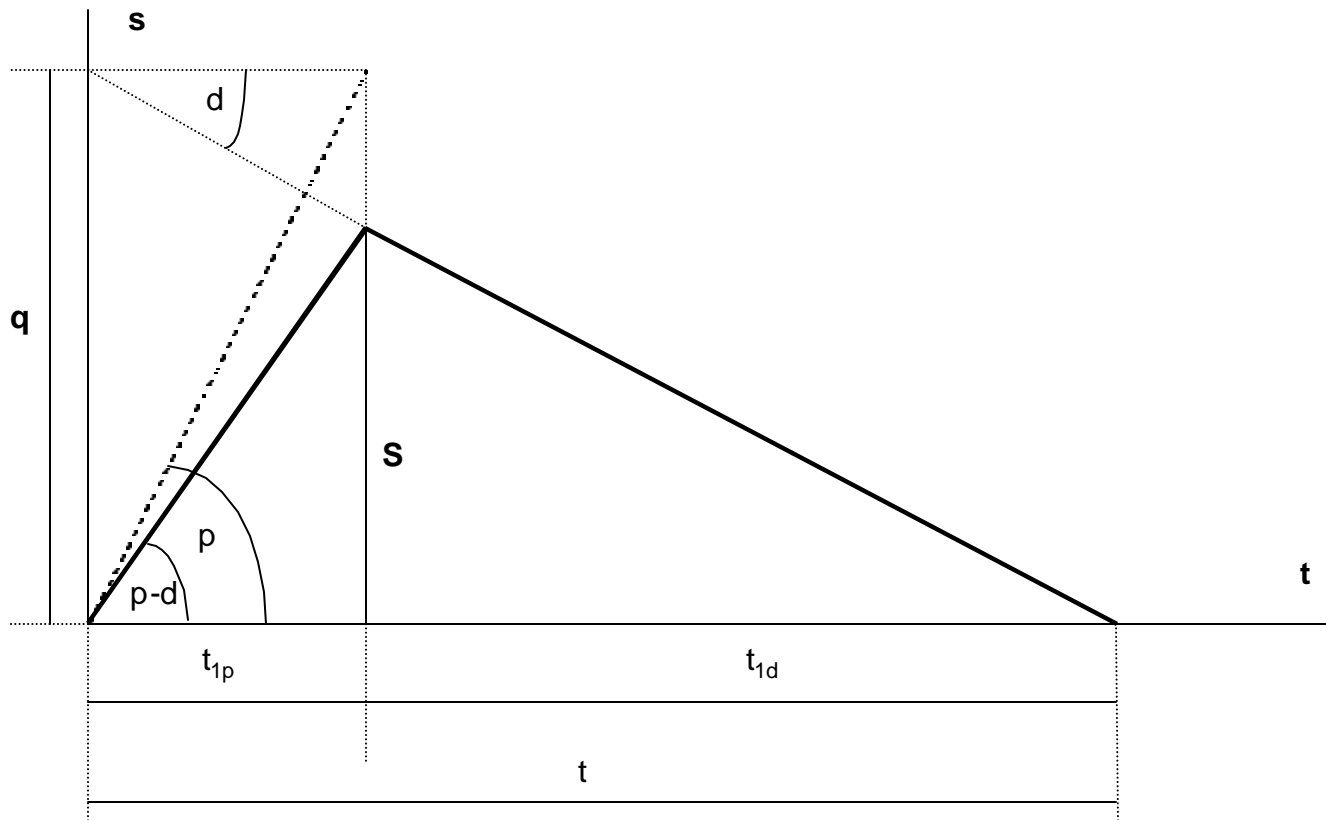

$$q = p \cdot t_{1p} \quad \Rightarrow \quad t_{1p} = \frac{q}{p}$$

$$S = (p - d) \cdot t_{1p} \quad \Rightarrow \quad S = (p - d) \cdot \frac{q}{p} \quad \Rightarrow \quad S = q \cdot \left(1 - \frac{d}{p}\right)$$

$$\text{CTE}_i = b \cdot q + \frac{1}{2} \cdot q \cdot \left(1 - \frac{d}{p}\right) \cdot c_1 \cdot t + k$$

$$n = \frac{D}{q} = \frac{T}{t}$$

$$\text{CTE} = b \cdot D + \frac{1}{2} \cdot q \cdot \left(1 - \frac{d}{p}\right) \cdot c_1 \cdot T + k \cdot \frac{D}{q}$$

$$\frac{\partial \text{CTE}}{\partial q} = \frac{1}{2} \cdot c_1 \cdot \left(1 - \frac{d}{p}\right) \cdot T - k \cdot \frac{D}{q^2} = 0$$

$$q_o = \sqrt{\frac{2 \cdot k \cdot D}{T \cdot c_1 \cdot \left(1 - \frac{d}{p}\right)}}$$

$$\text{CTE}_o = b \cdot D + \sqrt{2 \cdot k \cdot D \cdot T \cdot c_1 \cdot \left(1 - \frac{d}{p}\right)}$$

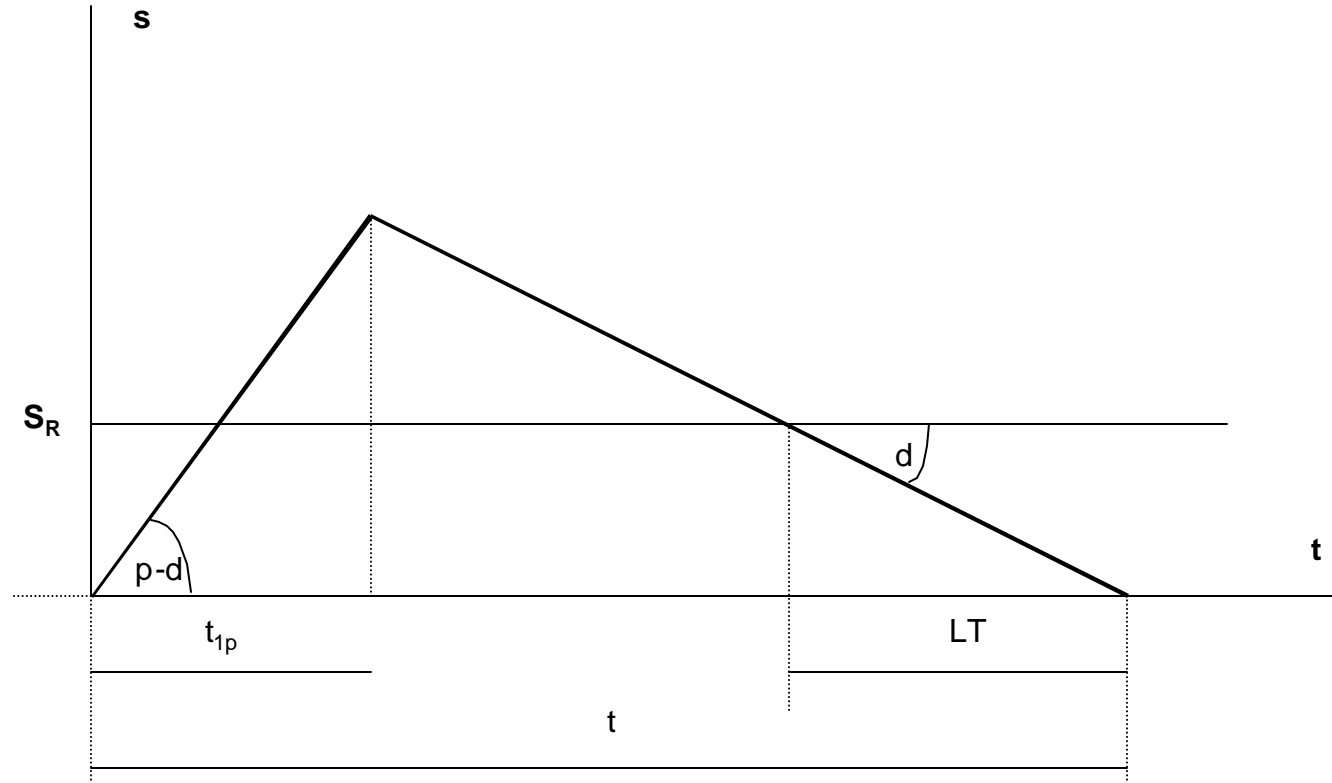

$$\text{Si } LT \leq t - t_{1p} \quad \Rightarrow \quad S_R = LT \cdot d$$

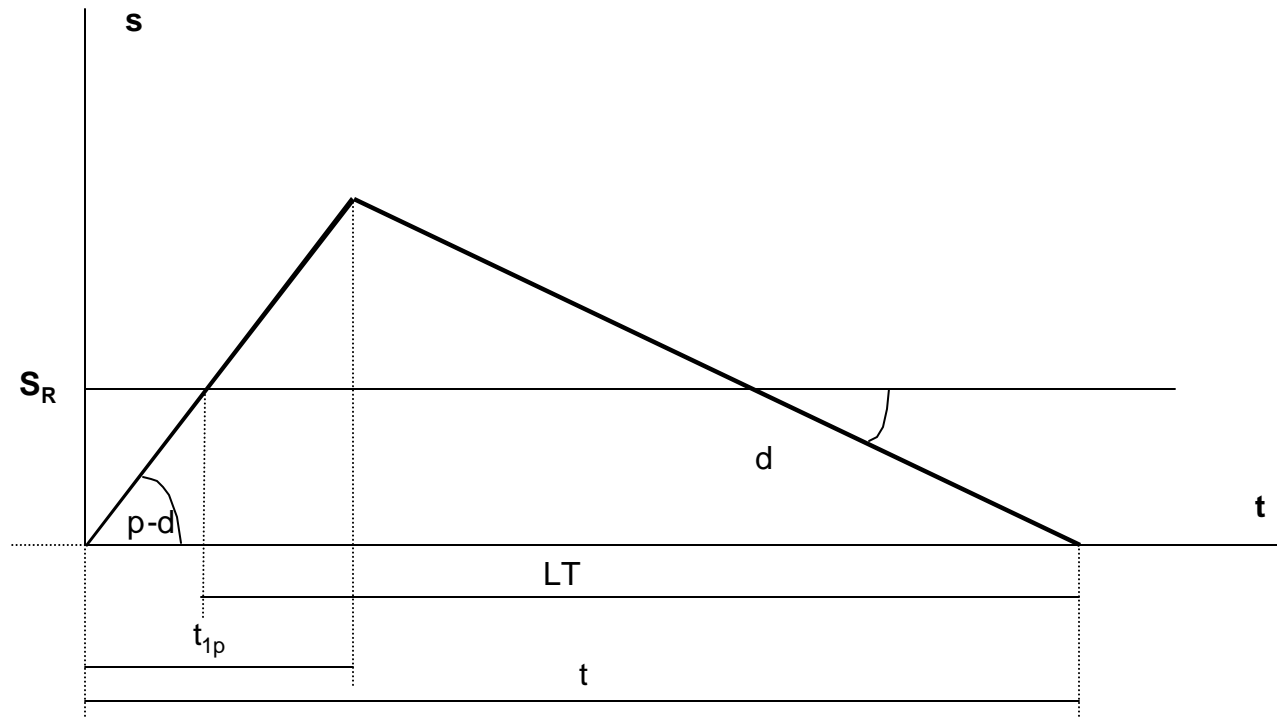

$$\text{Si } LT > t - t_{1p} \implies S_R = (t - LT) \cdot (p - d)$$

REAPROVISIONAMIENTO NO
INSTANTÁNEO

+

STOCK DE PROTECCIÓN

$$\text{CTE} = b \cdot D + \frac{1}{2} \cdot q \cdot \left(1 - \frac{d}{p}\right) \cdot c_1 \cdot T + k \cdot \frac{D}{q} + S_p \cdot c_1 \cdot T \quad \rightarrow \quad q_o = \sqrt{\frac{2 \cdot k \cdot D}{T \cdot c_1 \cdot \left(1 - \frac{d}{p}\right)}}$$

$$\text{CTE}_o = b \cdot D + \sqrt{2 \cdot k \cdot D \cdot T \cdot c_1 \cdot \left(1 - \frac{d}{p}\right)} + S_p \cdot c_1 \cdot T$$

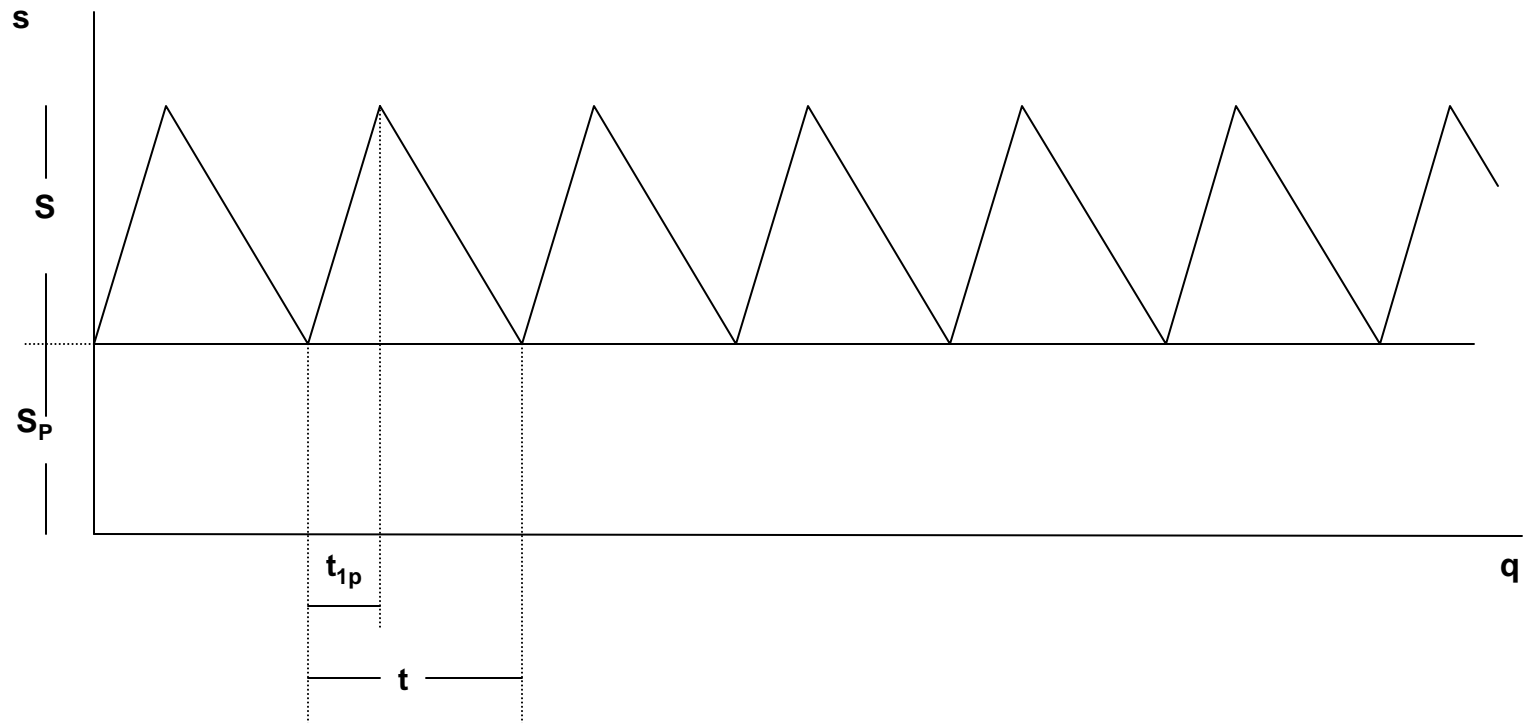

$$\text{Si } LT \leq t - t_{1P} \quad \longrightarrow \quad S_R = LT \cdot d + S_P$$

$$\text{Si } LT > t - t_{1P} \quad \longrightarrow \quad S_R = (t - LT) \cdot (p - d) + S_P$$

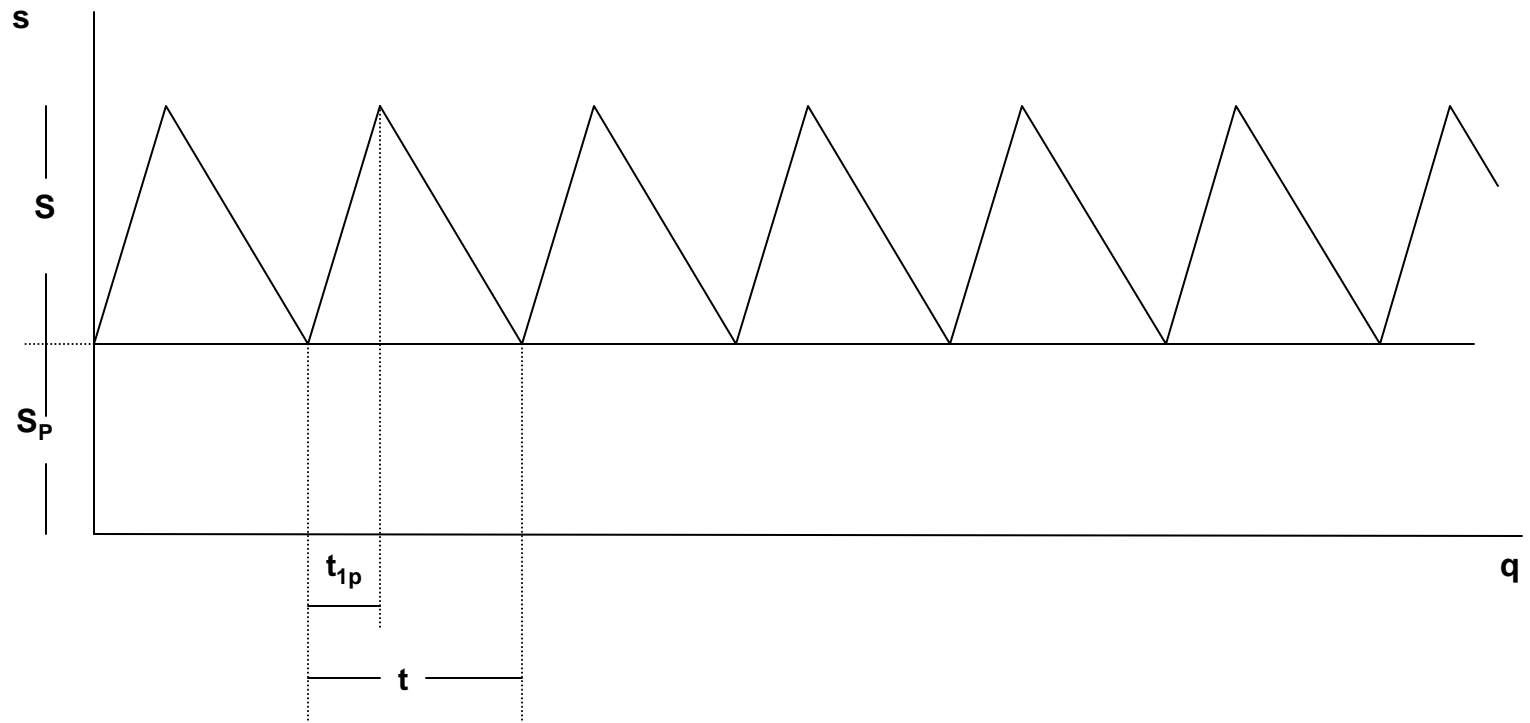

REAPROVISIONAMIENTO NO
INSTANTÁNEO

+

AGOTAMIENTO ADMITIDO

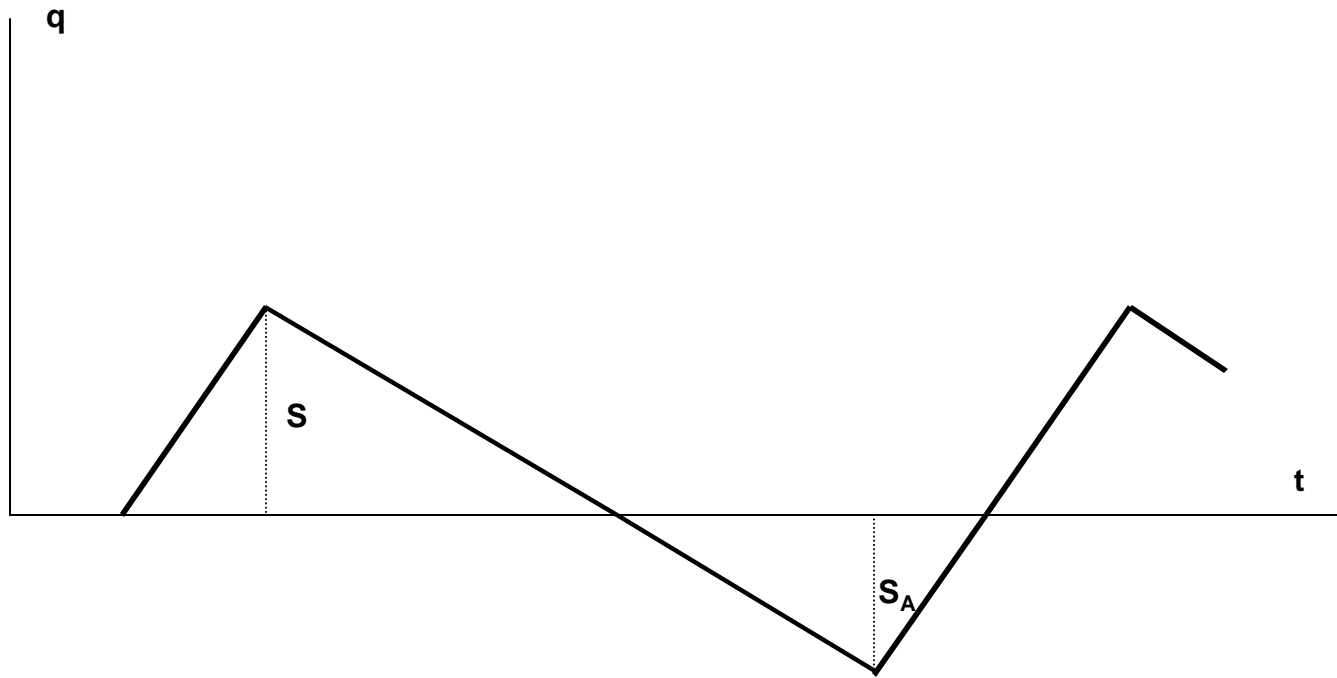

$$\text{CTE} = b \cdot D + \frac{1}{2} \cdot \frac{\left[q \cdot \left(1 - \frac{d}{p} \right) - S_A \right]^2 \cdot c_1 \cdot T}{q \cdot \left(1 - \frac{d}{p} \right)} + \frac{k \cdot D}{q} + \frac{1}{2} \cdot \frac{S_A^2 \cdot c_2 \cdot T}{q \cdot \left(1 - \frac{d}{p} \right)}$$

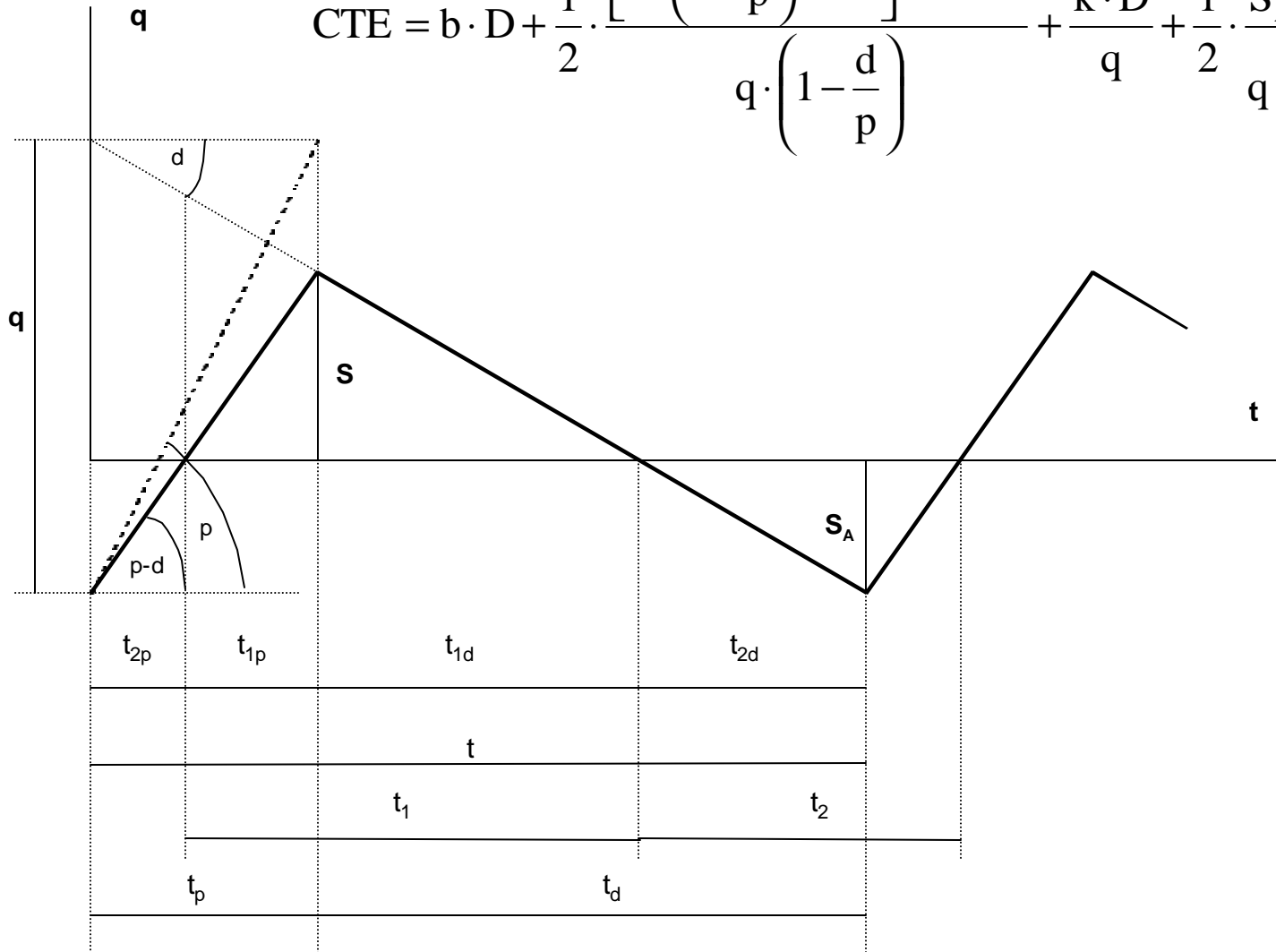

$$q_o = \sqrt{\frac{2 \cdot k \cdot D}{T \cdot c_1 \cdot \left(1 - \frac{d}{p}\right)}} \cdot \sqrt{\frac{c_1 + c_2}{c_2}}$$

$$S_{A_o} = \frac{c_1 \cdot q_o \cdot \left(1 - \frac{d}{p}\right)}{c_1 + c_2}$$

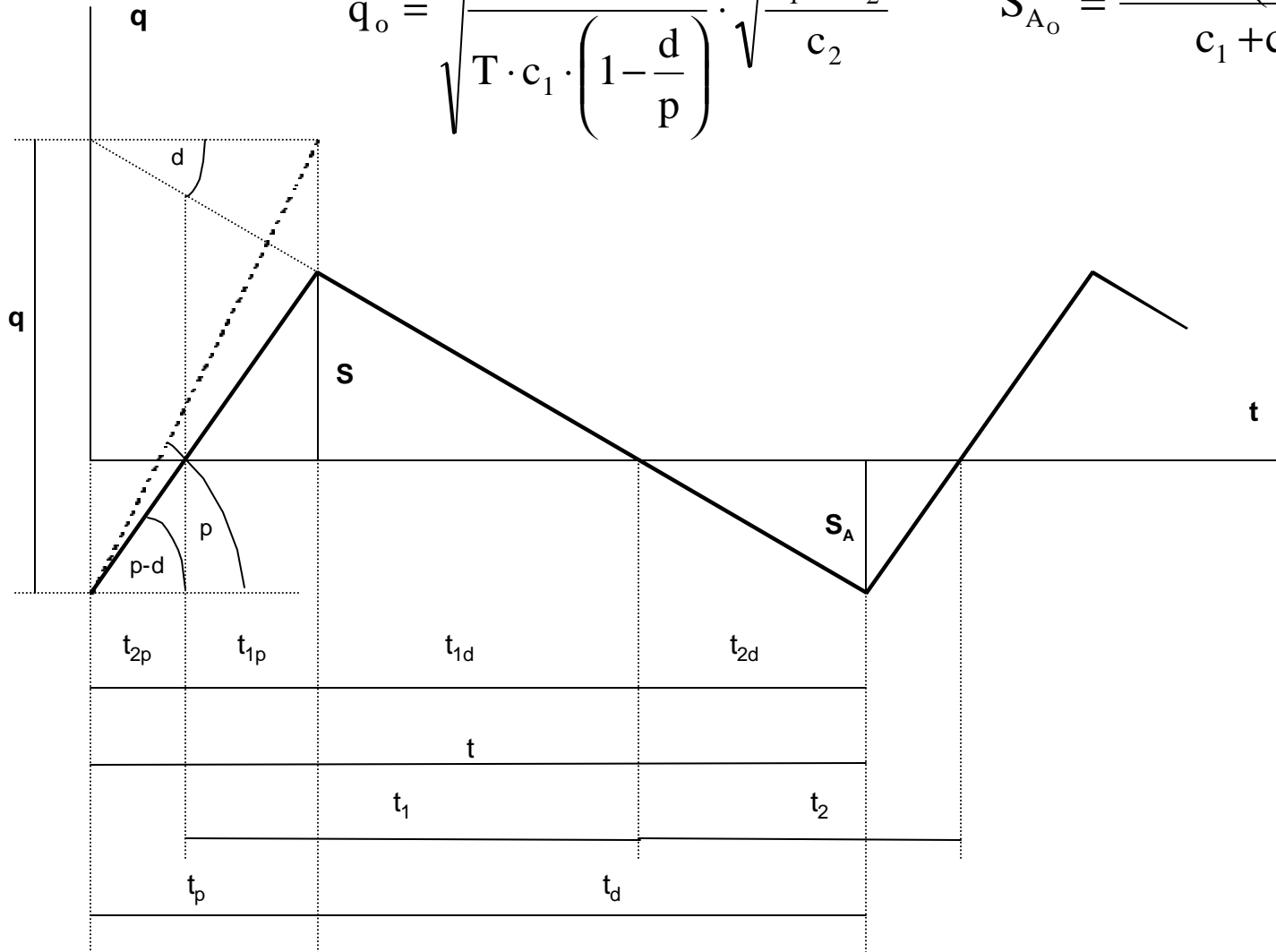

$$S_o = q_o \cdot \left(1 - \frac{d}{p}\right) \cdot \left(1 - \frac{c_1}{c_1 + c_2}\right)$$

$$CTE_o = b \cdot D + \sqrt{2 \cdot k \cdot D \cdot T \cdot c_1 \cdot \left(1 - \frac{d}{p}\right) \cdot \sqrt{\frac{c_2}{c_1 + c_2}}}$$

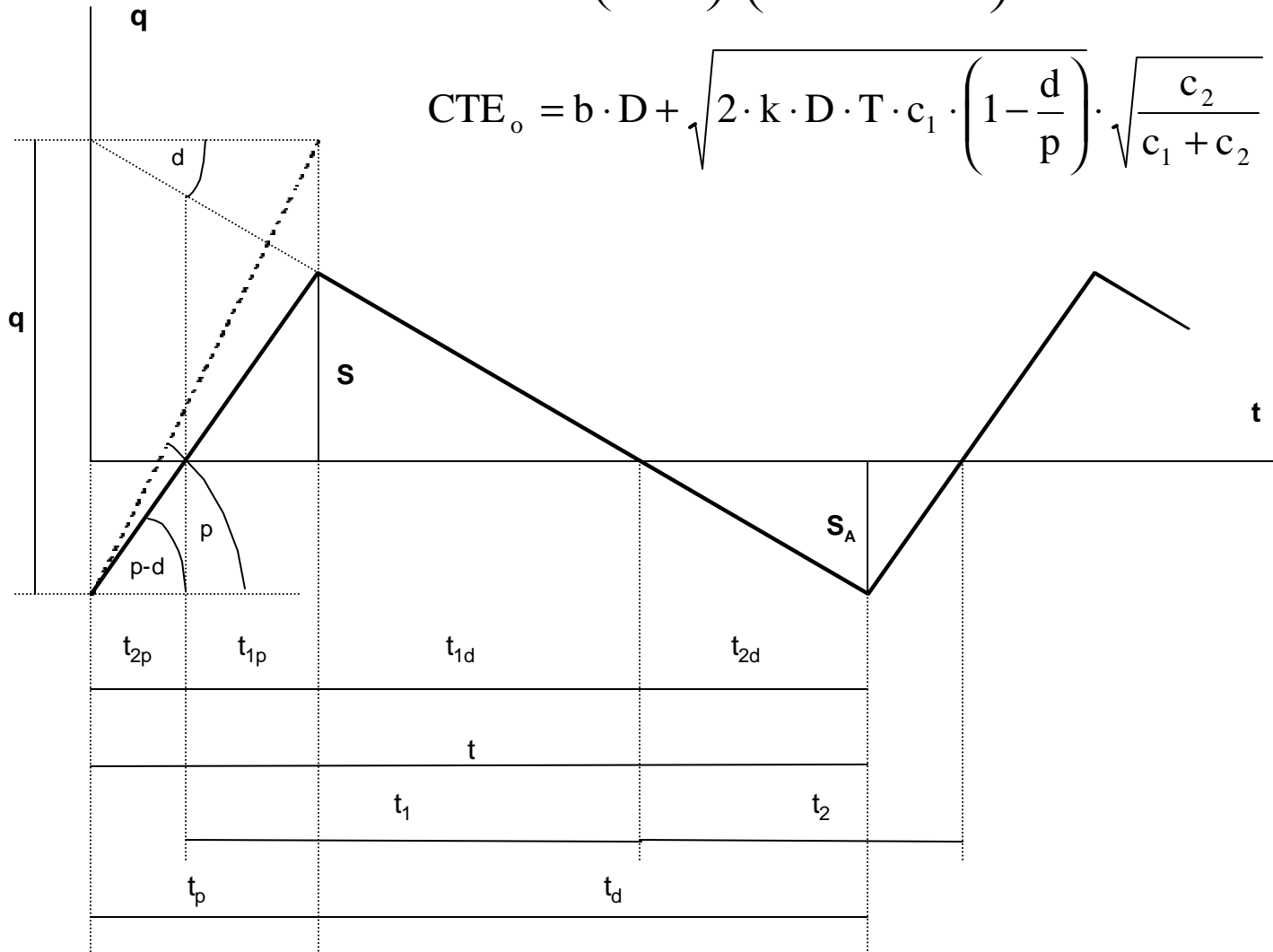

Si $LT \leq t_d$ \implies

$S_R = LT \cdot d - S_A$

Si $LT > t_d$ \implies

$S_R = (t - LT) \cdot (p - d) - S_A$

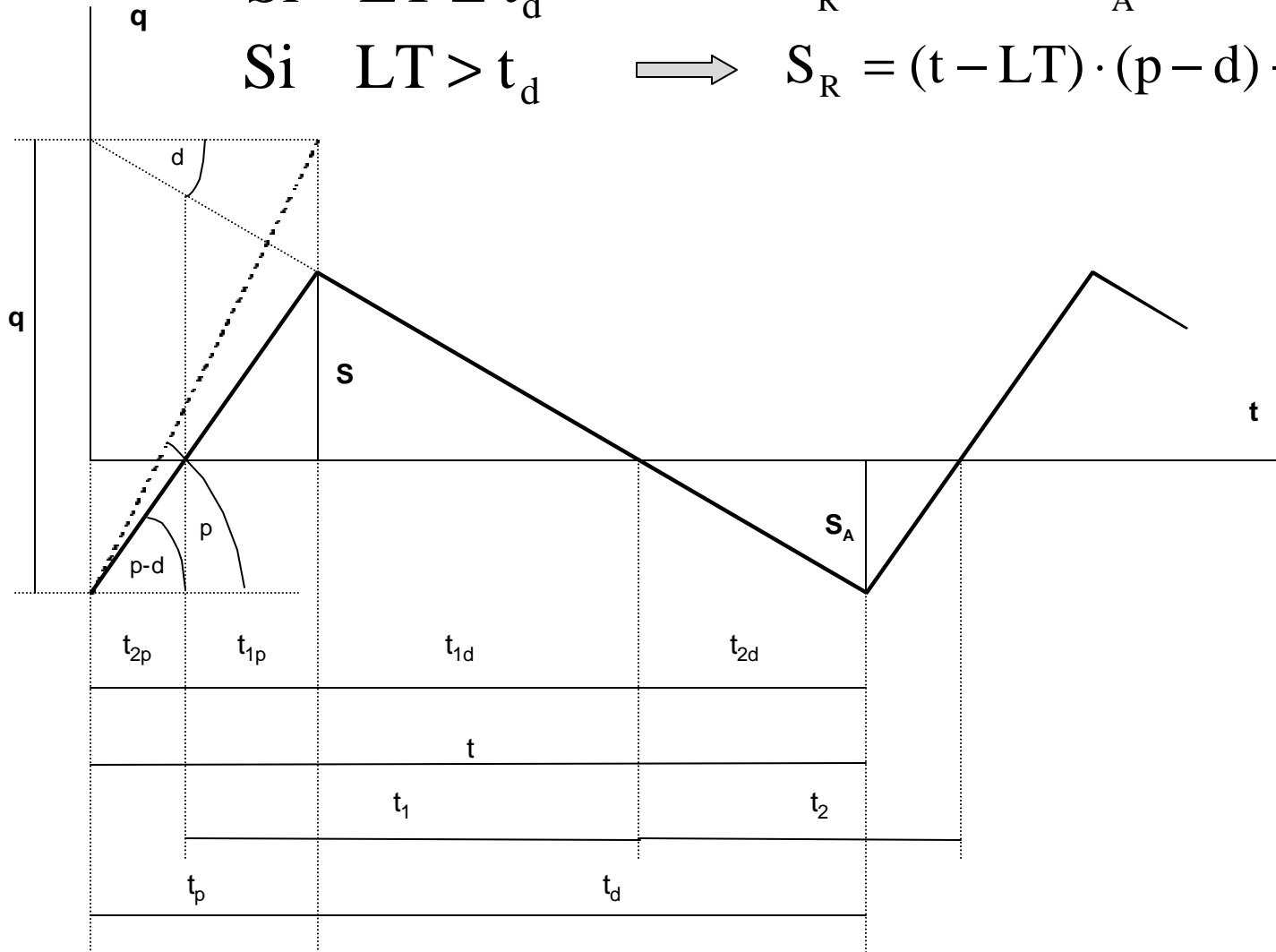

COSTOS RELEVANTES

b

$$c_1 = c'_1 + b \cdot i$$

k

C_2

f_2

F_2

$$\text{CTE}_i = b \cdot q + \frac{1}{2} \cdot S \cdot c_1 \cdot t_1 + \frac{1}{2} \cdot S_A \cdot c_2 \cdot t_2 + k + S_A \cdot f_2 + F_2$$

$$\text{CTE} = b \cdot D + \frac{1}{2} \cdot \frac{\left[q \cdot \left(1 - \frac{d}{p} \right) - S_A \right]^2}{q \cdot \left(1 - \frac{d}{p} \right)} \cdot c_1 \cdot T + \frac{1}{2} \cdot \frac{S_A^2}{q \cdot \left(1 - \frac{d}{p} \right)} \cdot c_2 \cdot T + k \cdot \frac{D}{q} + S_A \cdot f_2 \cdot \frac{D}{q} + F_2 \cdot \frac{D}{q}$$

$$q_o = \sqrt{\frac{2 \cdot (k + F_2 \cdot I_F) \cdot D}{T \cdot c_1 \cdot \left(1 - \frac{d}{p} \right)} - \frac{(f_2 \cdot D)^2}{c_1 \cdot (c_1 + c_2)}} \cdot \sqrt{\frac{c_1 + c_2}{c_2}}$$

$$S_{A_o} = \frac{(c_1 \cdot q_o - f_2 \cdot D) \cdot \left(1 - \frac{d}{p} \right)}{(c_1 + c_2)}$$

$$S_o = q_o \cdot \left(1 - \frac{d}{p} \right) - S_{A_o}$$

MODELO GENERAL

**AGREGANDO EL STOCK DE
PROTECCIÓN**

$$\text{CTE} = b \cdot D + \frac{1}{2} \cdot \frac{\left[q \cdot \left(1 - \frac{d}{p} \right) - S_A \right]^2}{q \cdot \left(1 - \frac{d}{p} \right)} \cdot c_1 \cdot T + \frac{1}{2} \cdot \frac{S_A^2}{q \cdot \left(1 - \frac{d}{p} \right)} \cdot c_2 \cdot T + k \cdot \frac{D}{q} + S_A \cdot f_2 \cdot \frac{D}{q} + F_2 \cdot \frac{D}{q} + S_P \cdot c_1 \cdot T$$

$$q_o = \sqrt{\frac{2 \cdot (k + F_2) \cdot D}{T \cdot c_1 \cdot \left(1 - \frac{d}{p} \right)} - \frac{(f_2 \cdot D)^2}{c_1 \cdot (c_1 + c_2)}} \cdot \sqrt{\frac{c_1 + c_2}{c_2}}$$

$$S_{A_o} = \frac{(c_1 \cdot q_o - f_2 \cdot D) \cdot \left(1 - \frac{d}{p} \right)}{(c_1 + c_2)}$$

$$S_o = q_o \cdot \left(1 - \frac{d}{p} \right) - S_{A_o}$$

$$S_{MÁX_o} = S_p + S_o$$

```

MIN = CTE;
CTE = b*D + 1/2 *(q*(1 d/p) Sa)^2/(q*(1 d/p))*c1*T + 1/2 * Sa^2 / (q*(1 d/p))*c2*T
      + k * D / q + Sa * f2 * D/q + F * D / q + Sp * c1 * T;
c1 = c1op + i*b;
T = 1;
n = D / q;
S = q * (1 d/p)- Sa;
Smax = S + Sp;
ti = t1 + t2;
t1 = t1d + t1p;
t2 = (t2d + t2p);
ti = q/D * T;
t1p = S / (p d);
t1d = S / d;
t2p = Sa / (p d);
t2d = Sa / d;
tp = t1p + t2p;
td = t1d + t2d;
c1 = c1op + i * b;

```

REAPROVISIONAMIENTO CONSTANTE



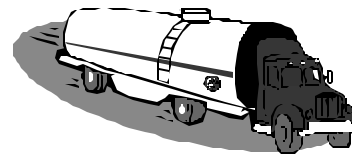
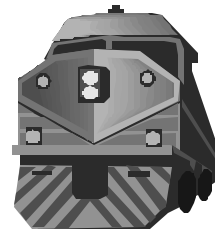
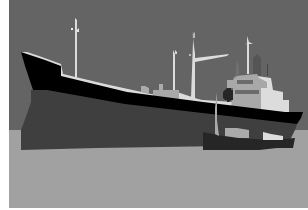
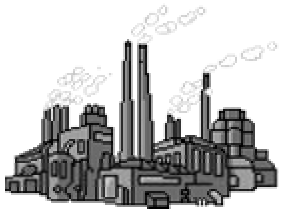

$$\text{CTE}_i = b \cdot q + \frac{1}{2} \cdot q \cdot c_1 \cdot t + k$$

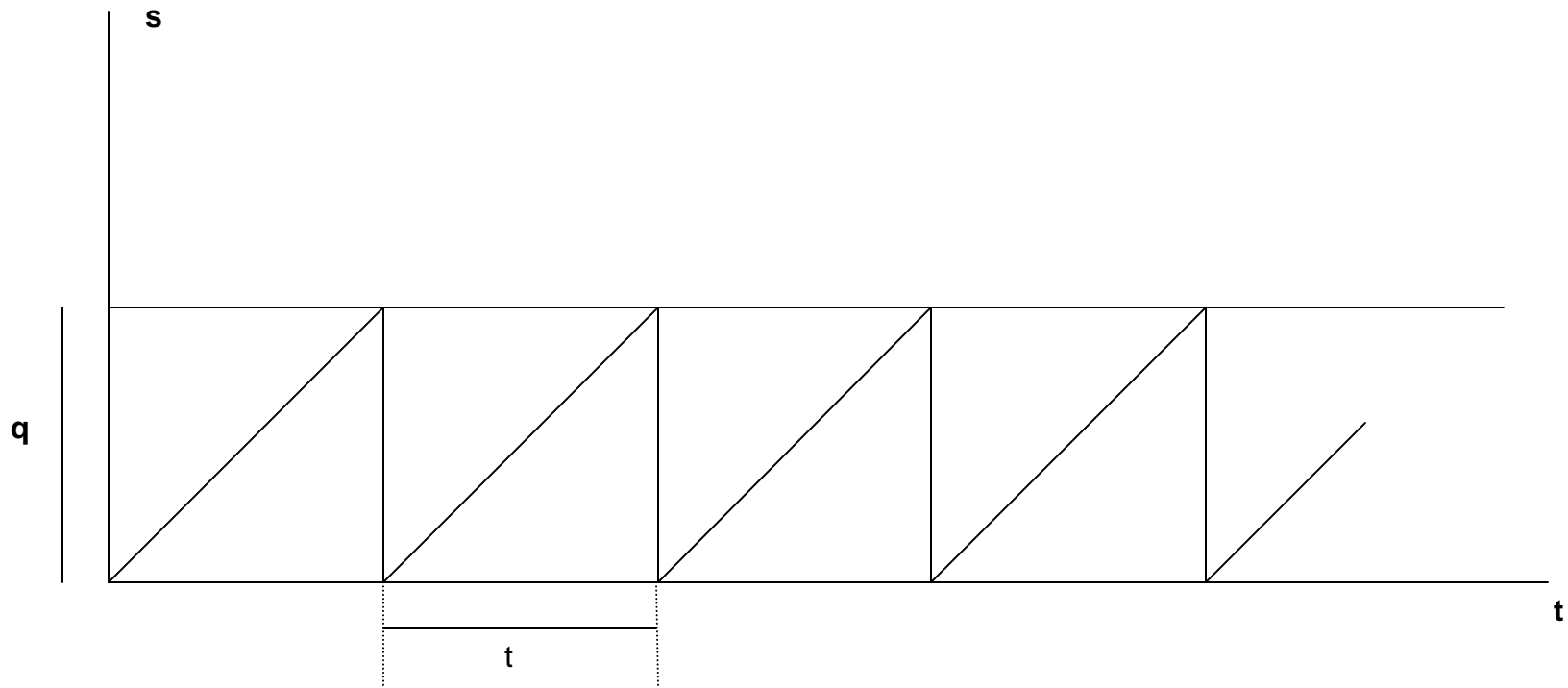

$$\text{CTE}_i = b \cdot q + \frac{1}{2} \cdot q \cdot c_1 \cdot t + k$$

$$n = \frac{P}{q} = \frac{T}{t}$$

$$\text{CTE} = b \cdot P + \frac{1}{2} \cdot q \cdot c_1 \cdot T + k \cdot \frac{P}{q}$$

$$q_o = \sqrt{\frac{2 \cdot k \cdot P}{T \cdot c_1}}$$

$$\text{CTE}_o = b \cdot D + \sqrt{2 \cdot k \cdot P \cdot T \cdot c_1}$$

$$S_R = q_0 - LT \cdot p$$

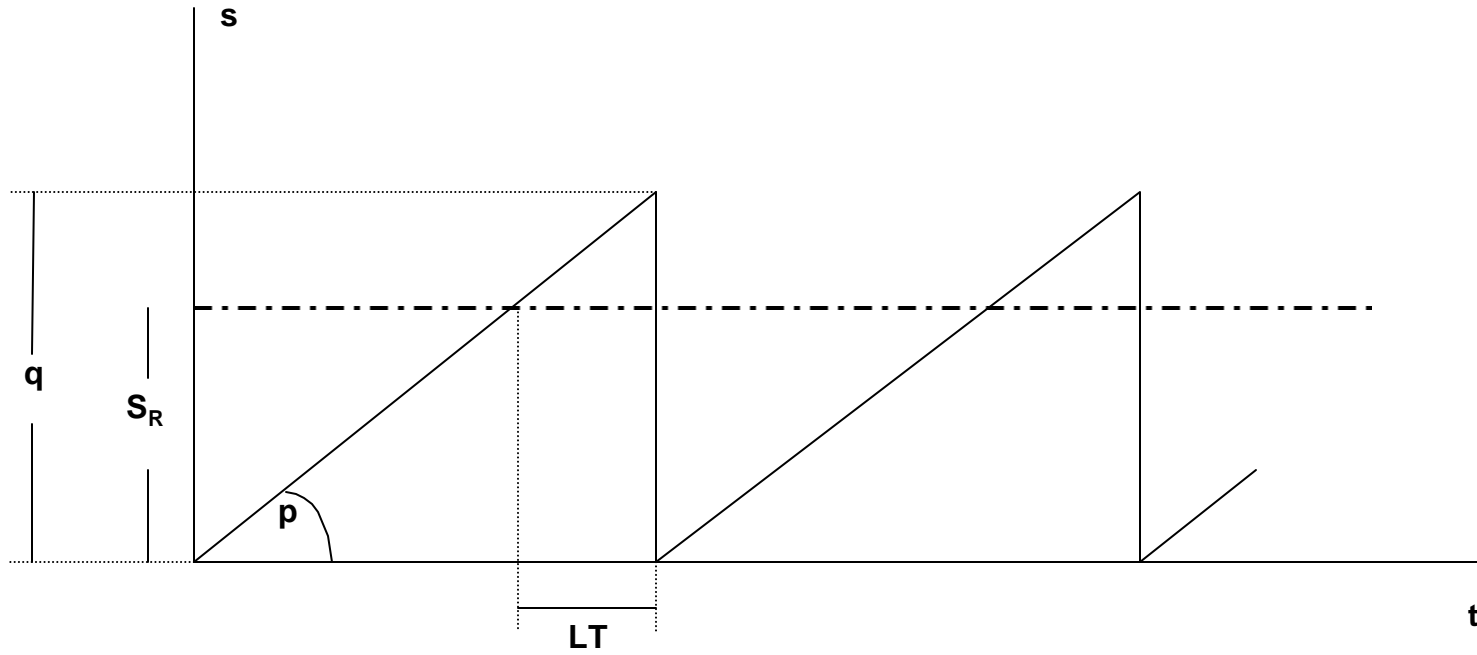

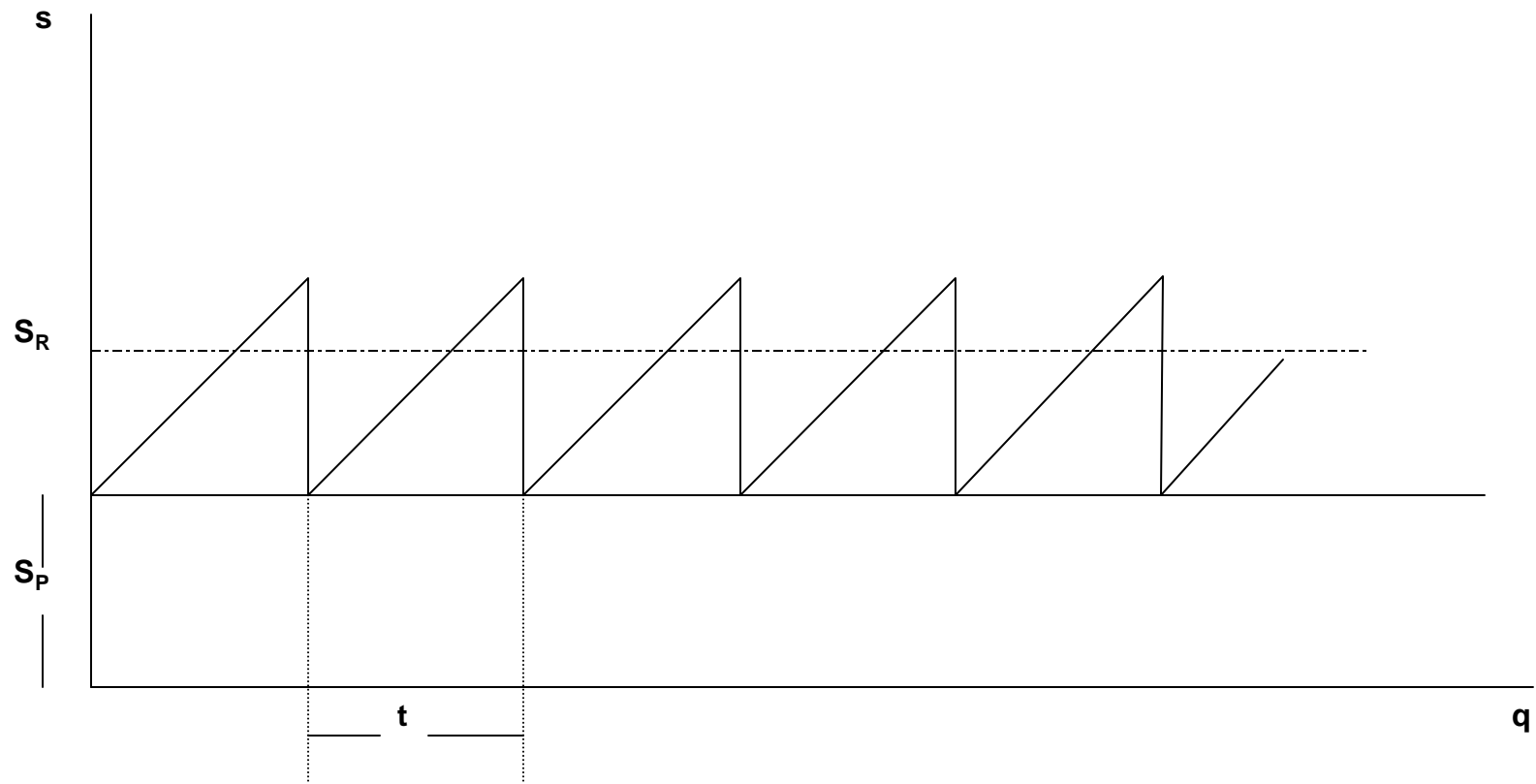

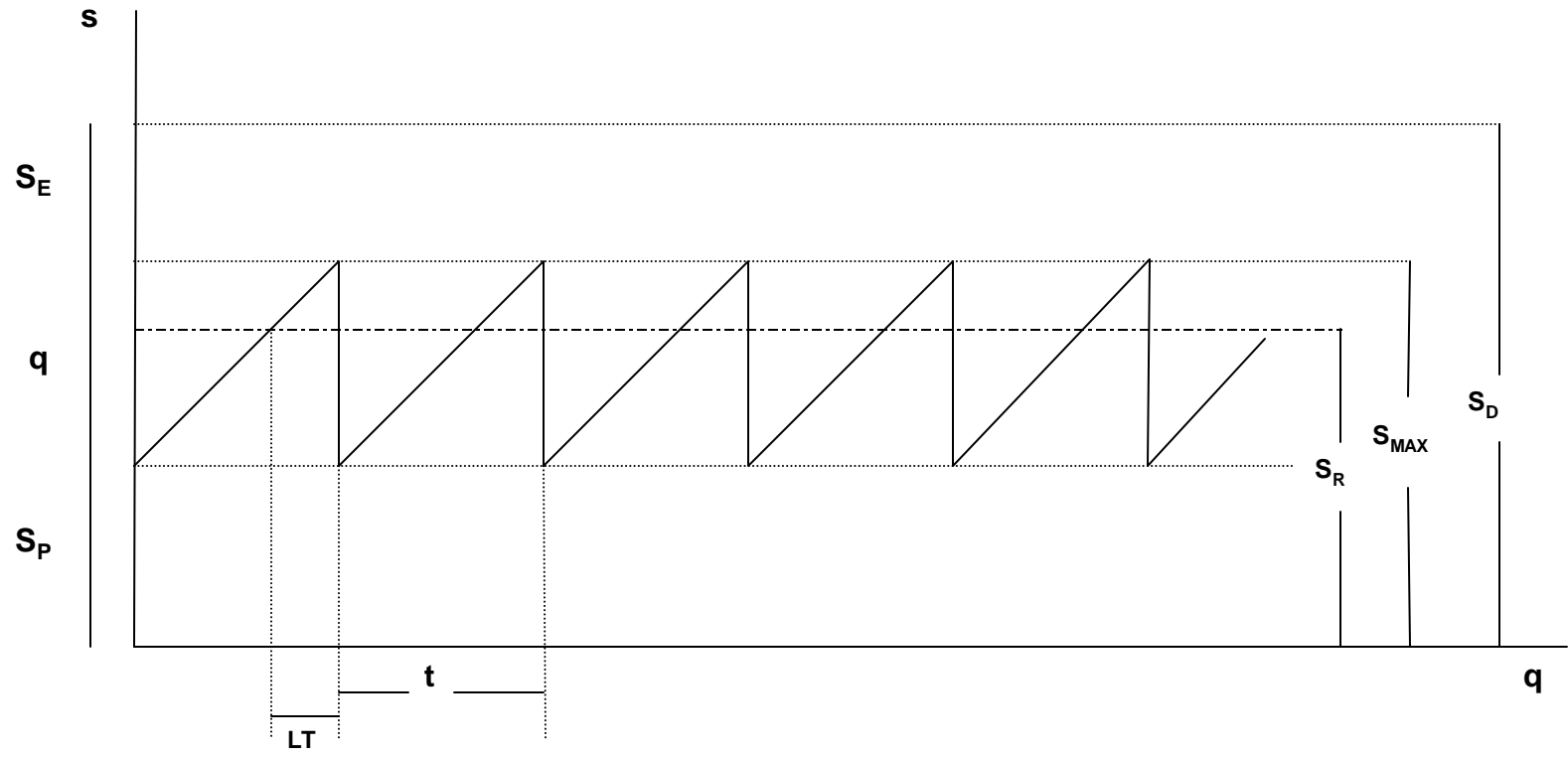

$$q_o = \sqrt{\frac{2 \cdot k \cdot P}{T \cdot c_1 \cdot \left(1 - \frac{p}{d}\right)}}$$

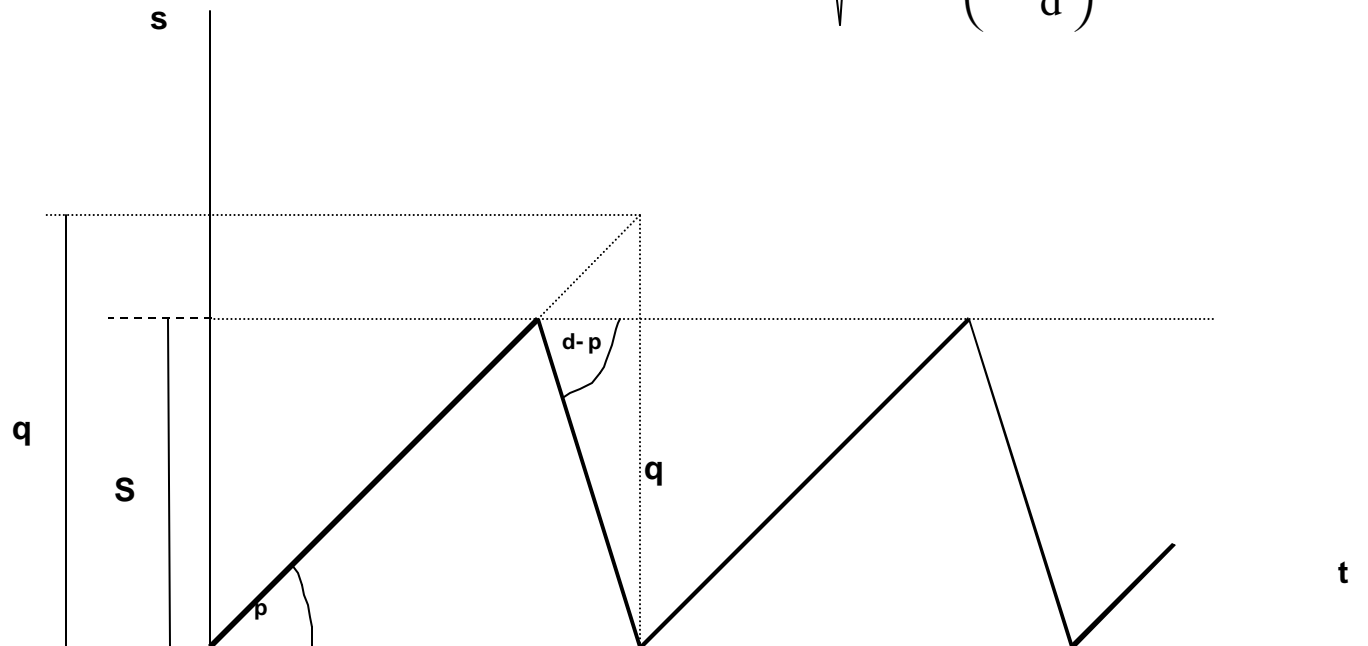

$$\text{Si } LT < t_{1P} \quad \longrightarrow \quad S_R = p \cdot (t_{1P} - LT)$$

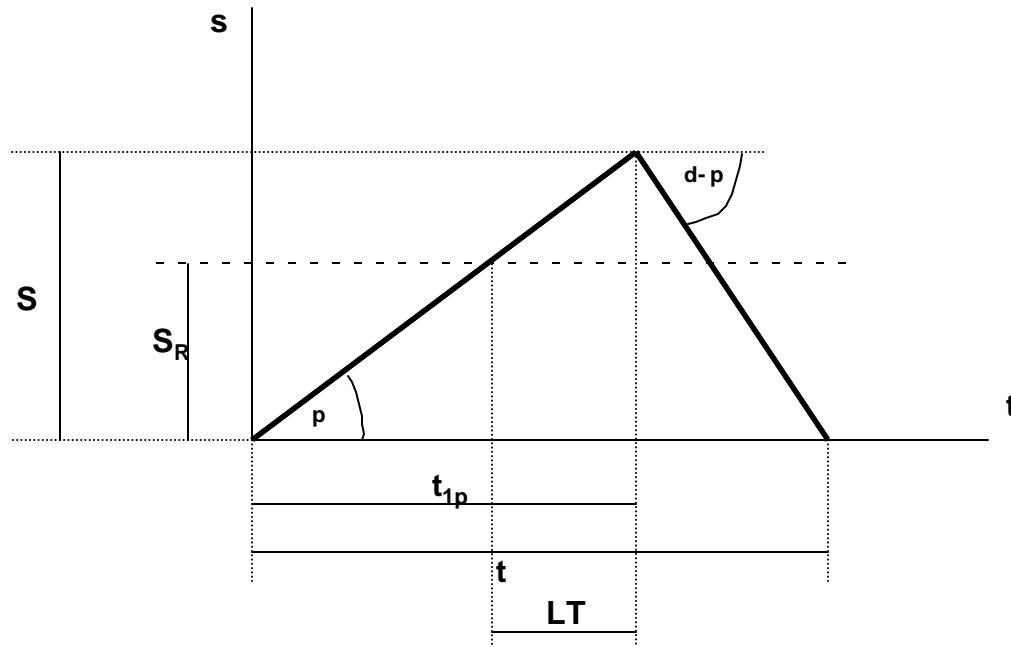

$$\text{Si } LT > t_{1P} \quad \longrightarrow \quad S_R = (LT - t_{1P}) \cdot (d - p)$$

