

Contador VGA controlado por UART

Sistemas Digitales / Taller de Sistemas Digitales

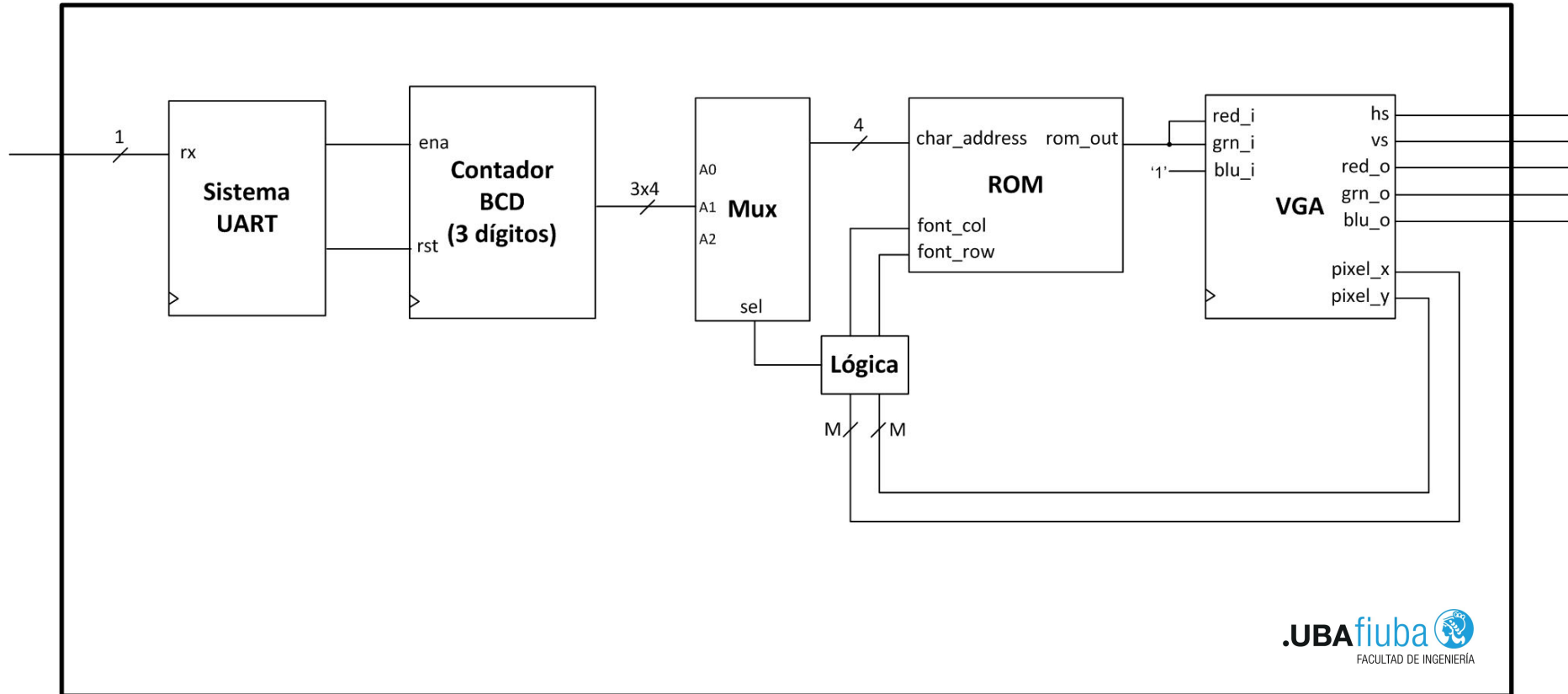

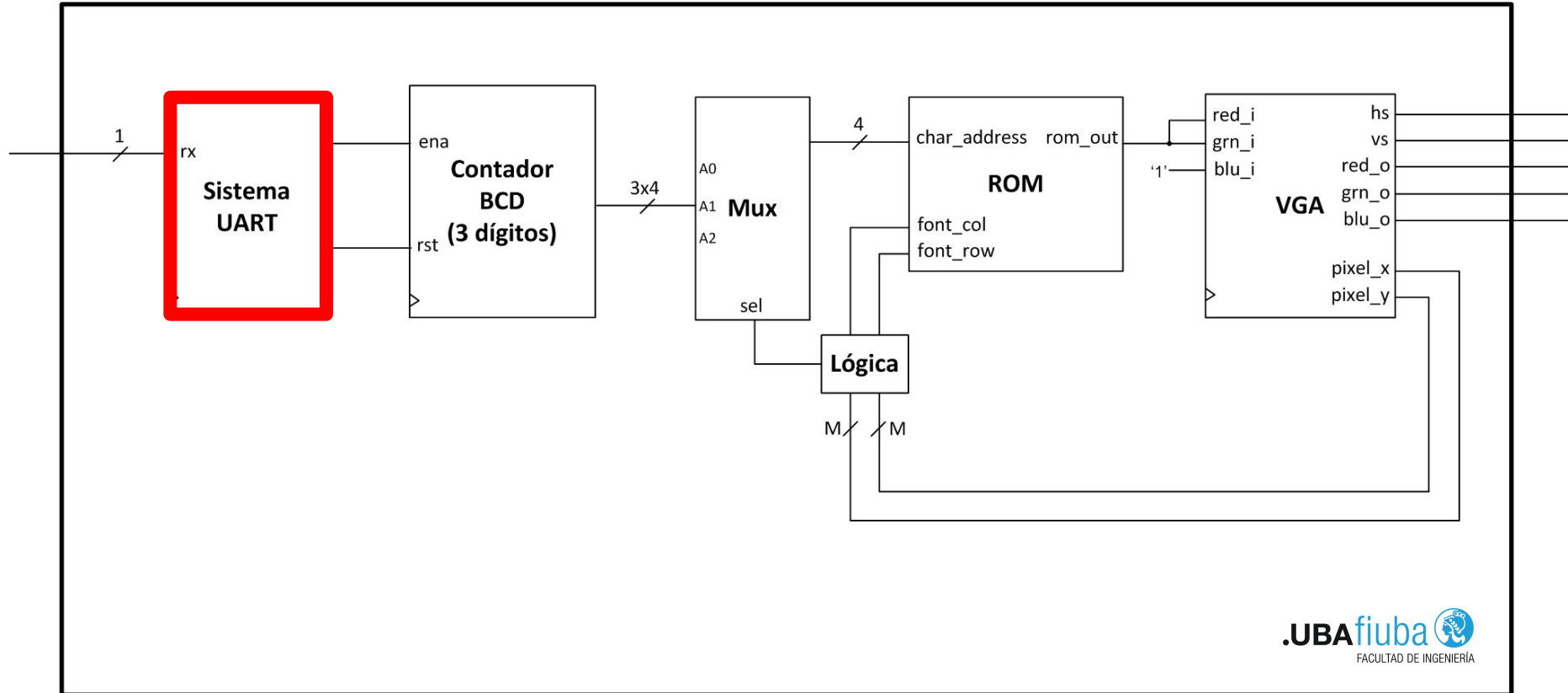

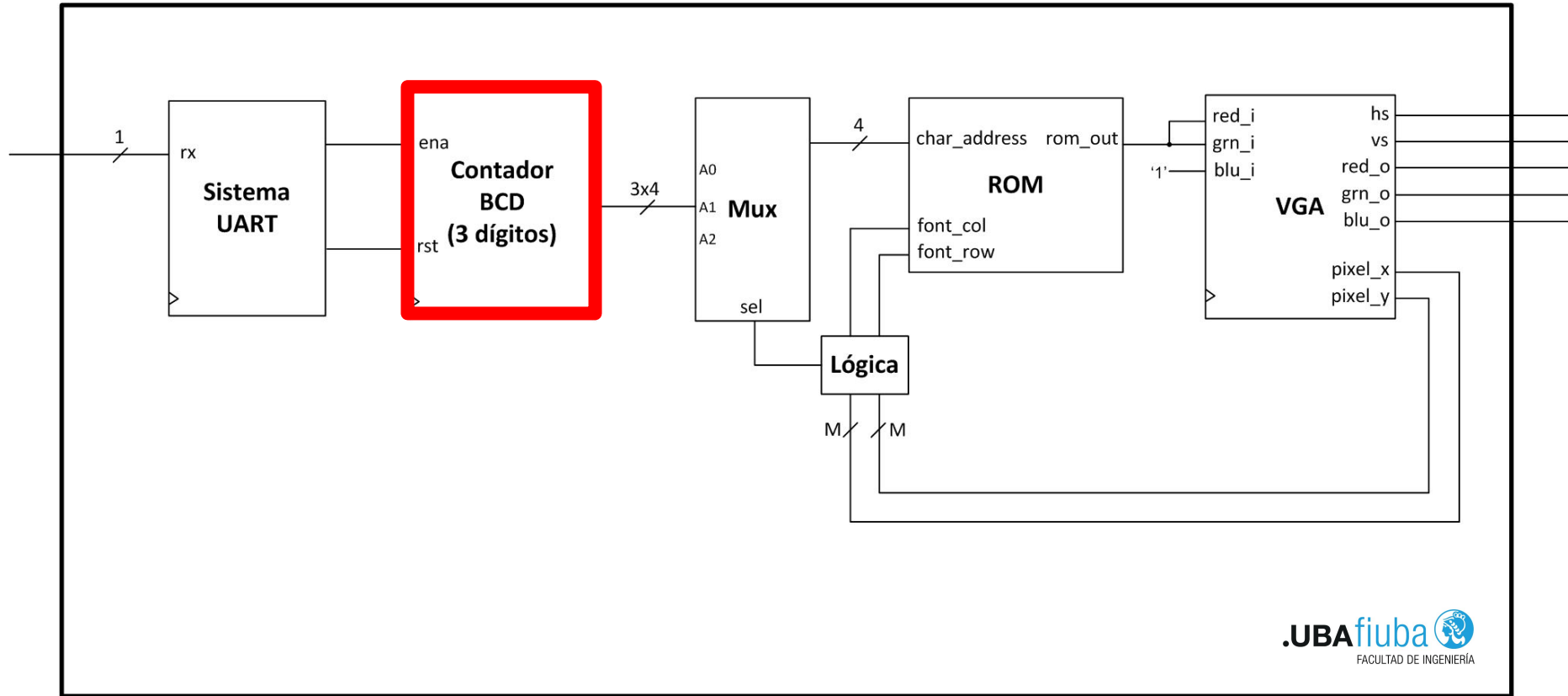

Contador BCD

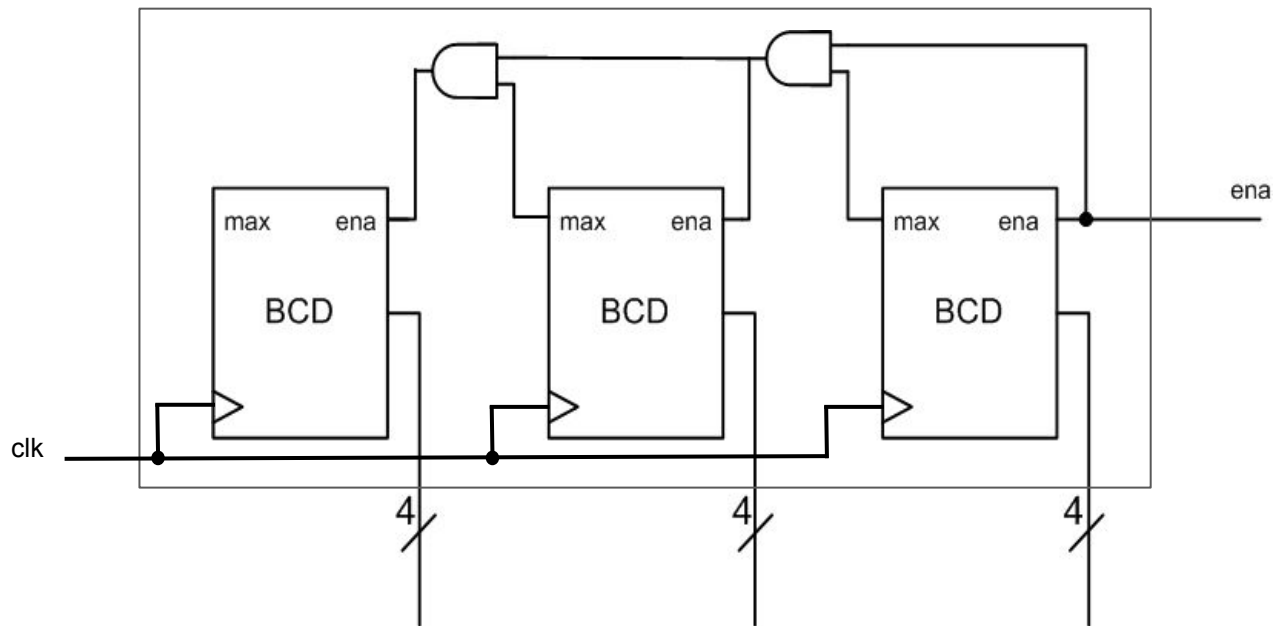

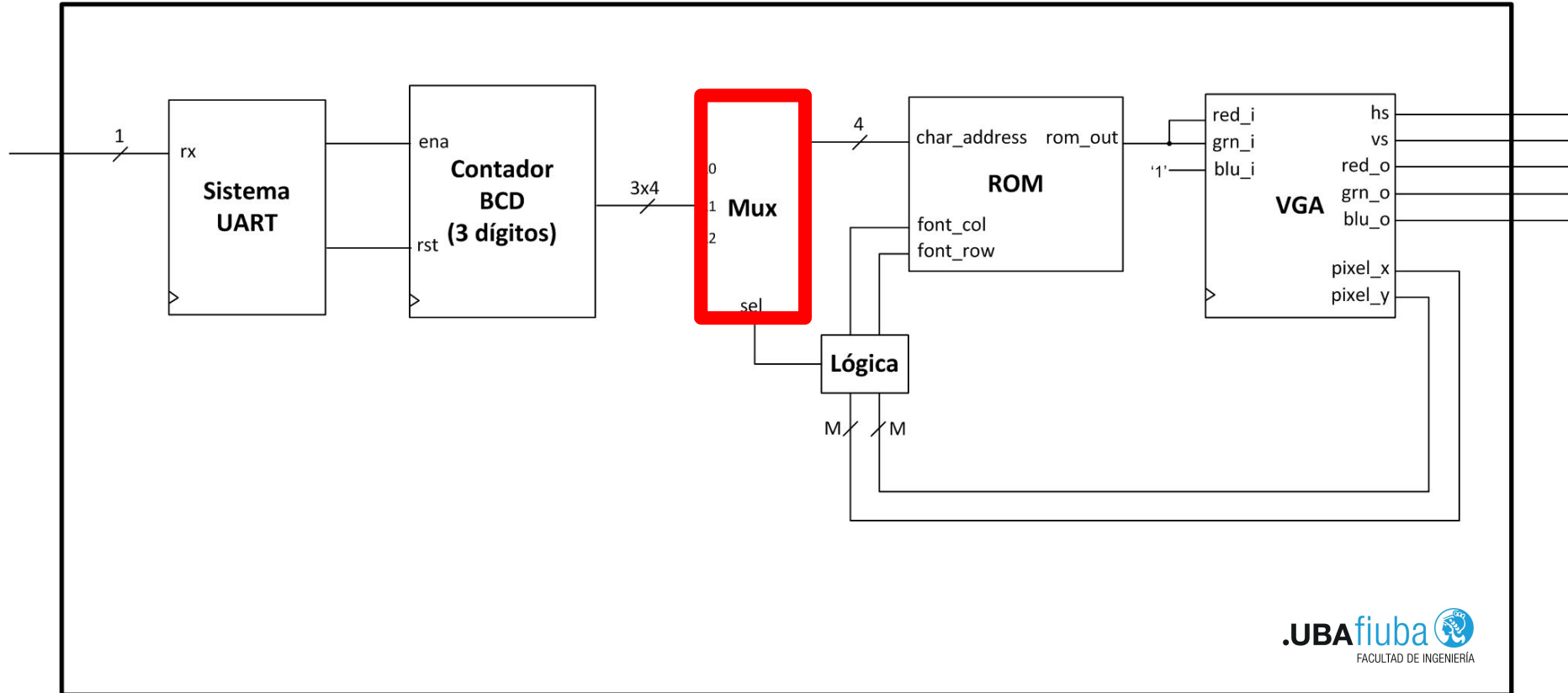

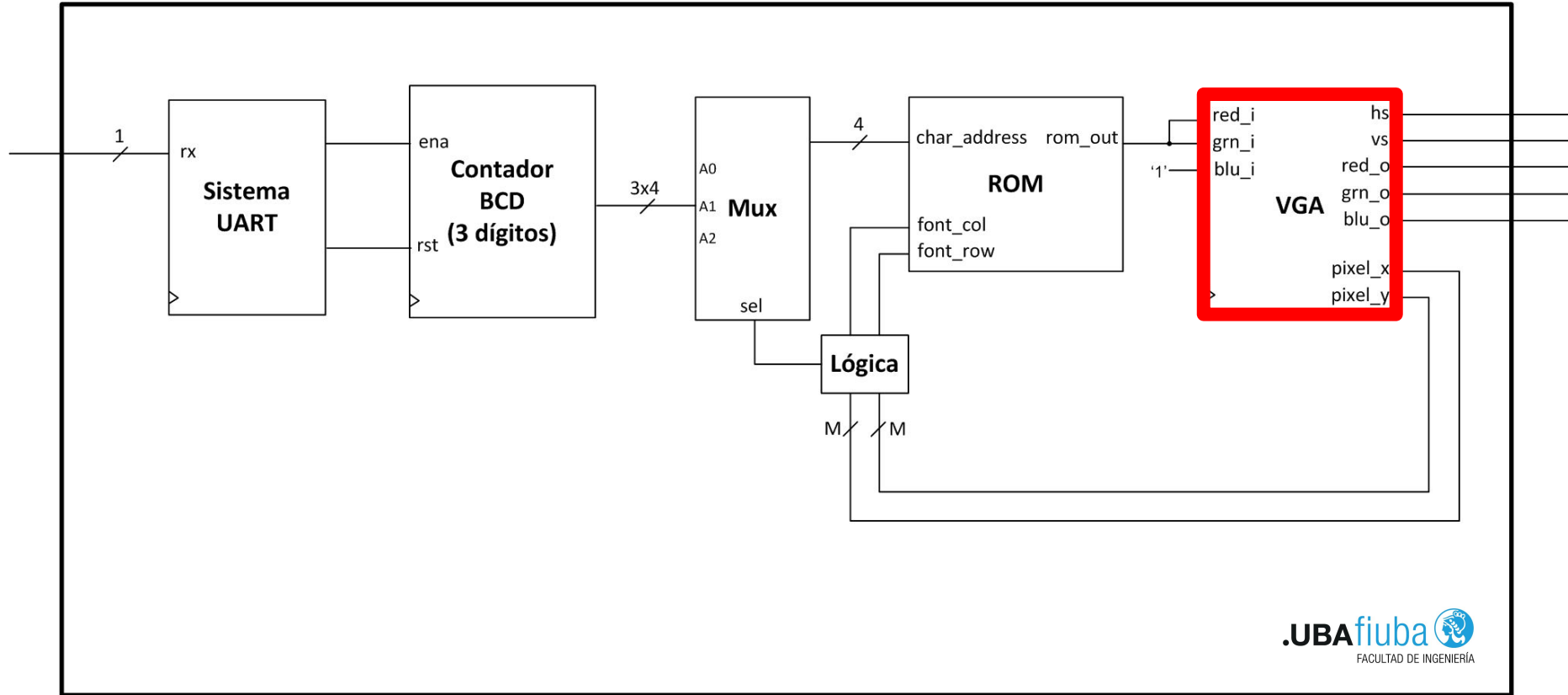

VGA

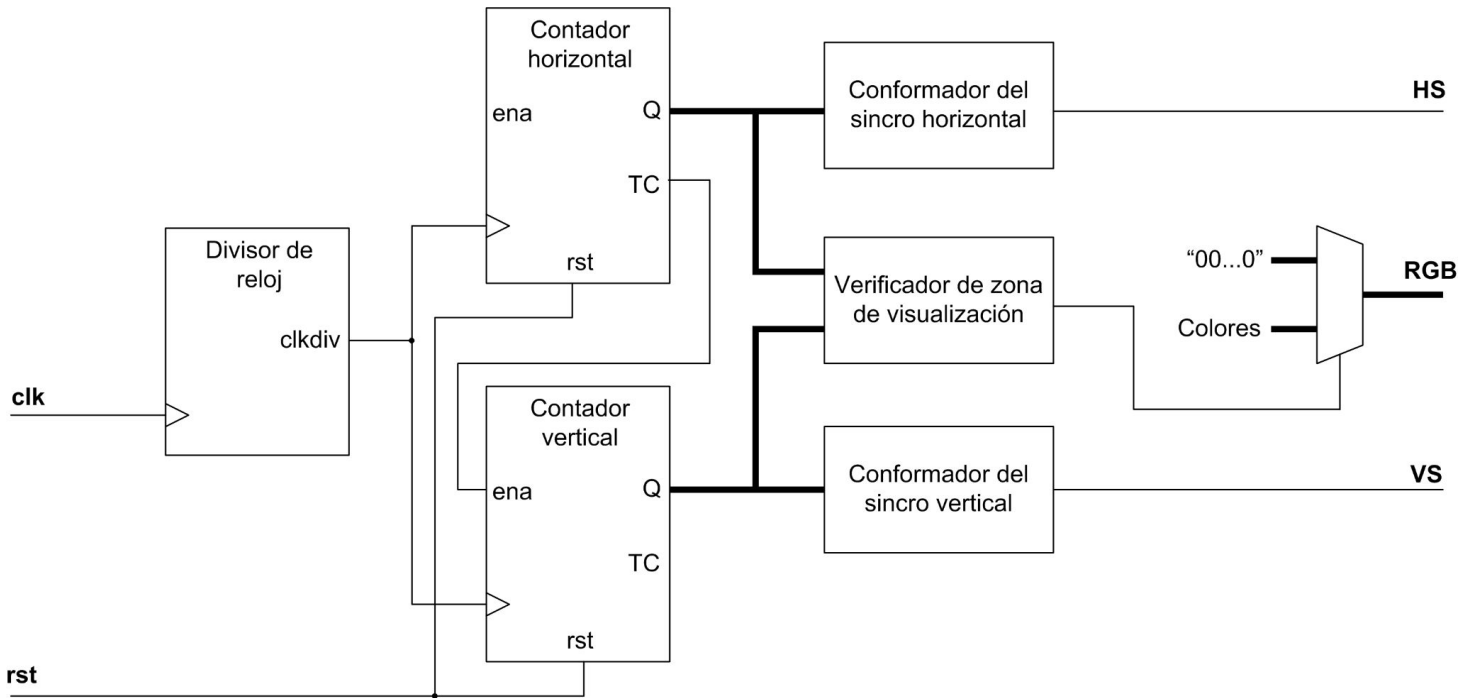

VGA: Frecuencia de operación de 25 MHz

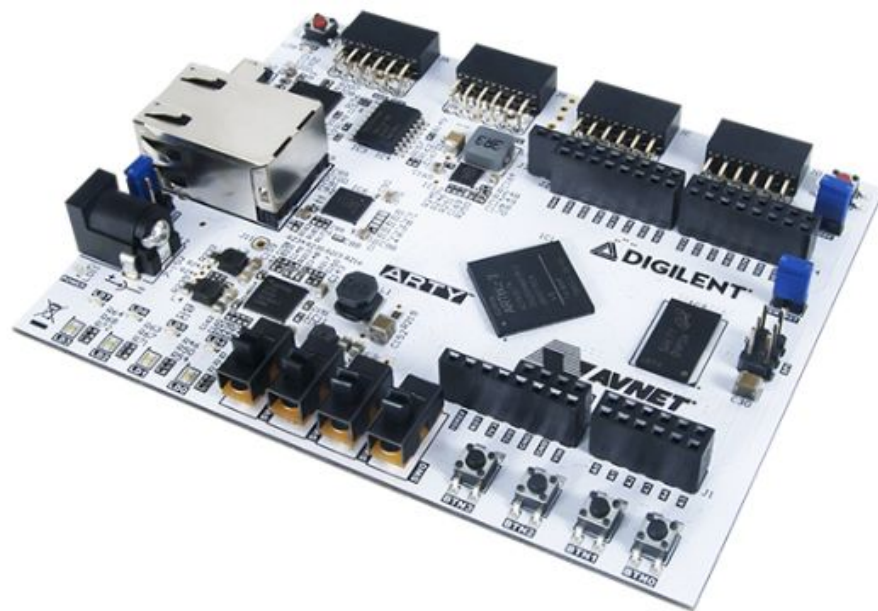
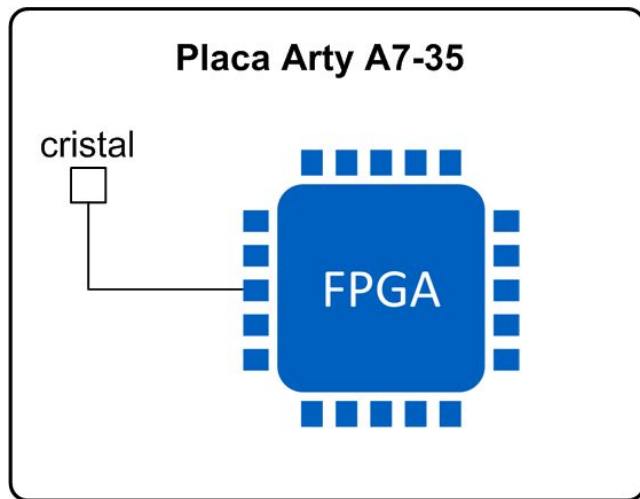

Frecuencia del cristal = 100 MHz

VGA: Frecuencia de operación de 25 MHz

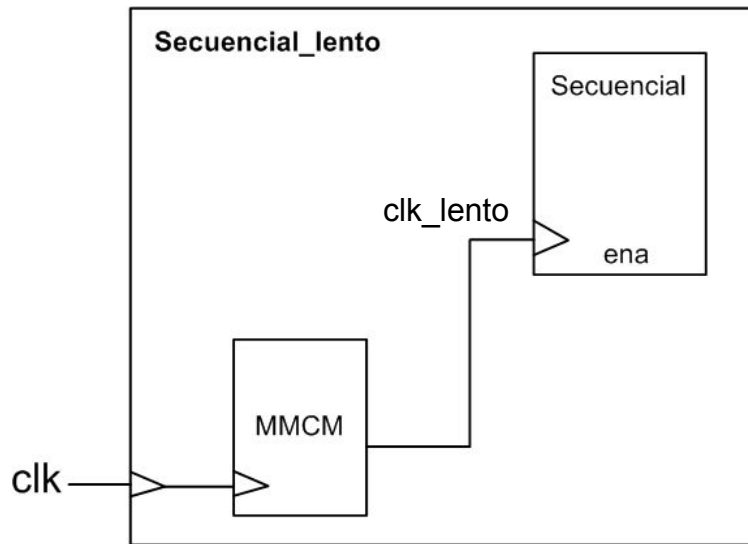

VGA: Frecuencia de operación de 25 MHz

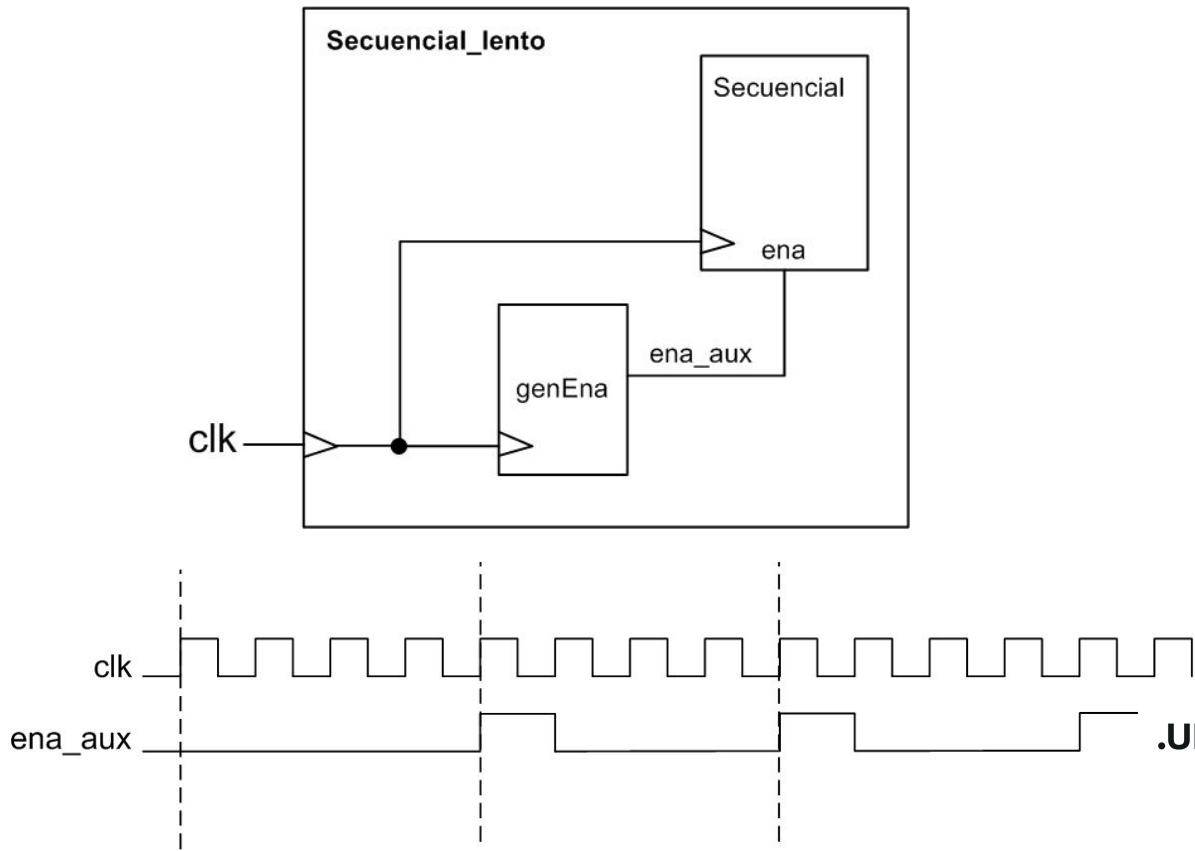

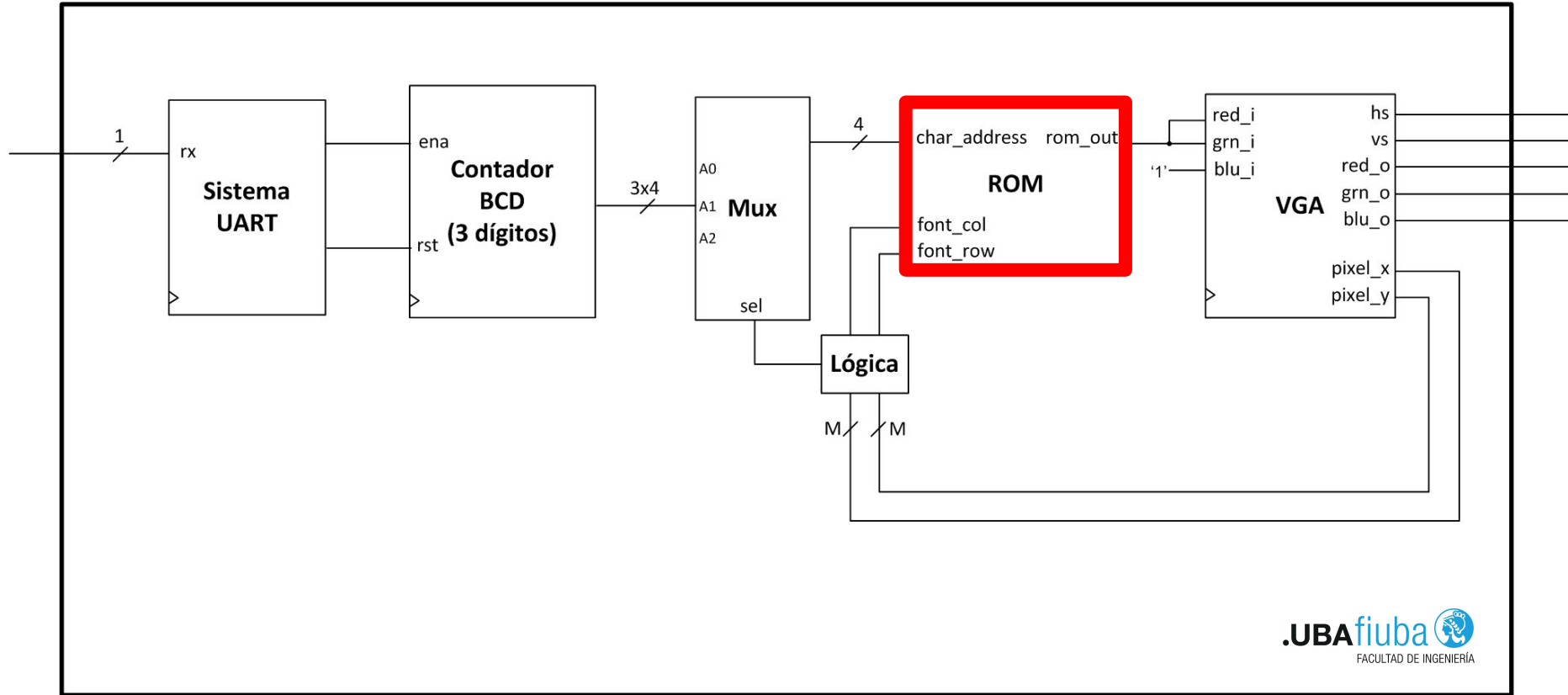

ROM

13 caracteres x 8 líneas = 104 líneas

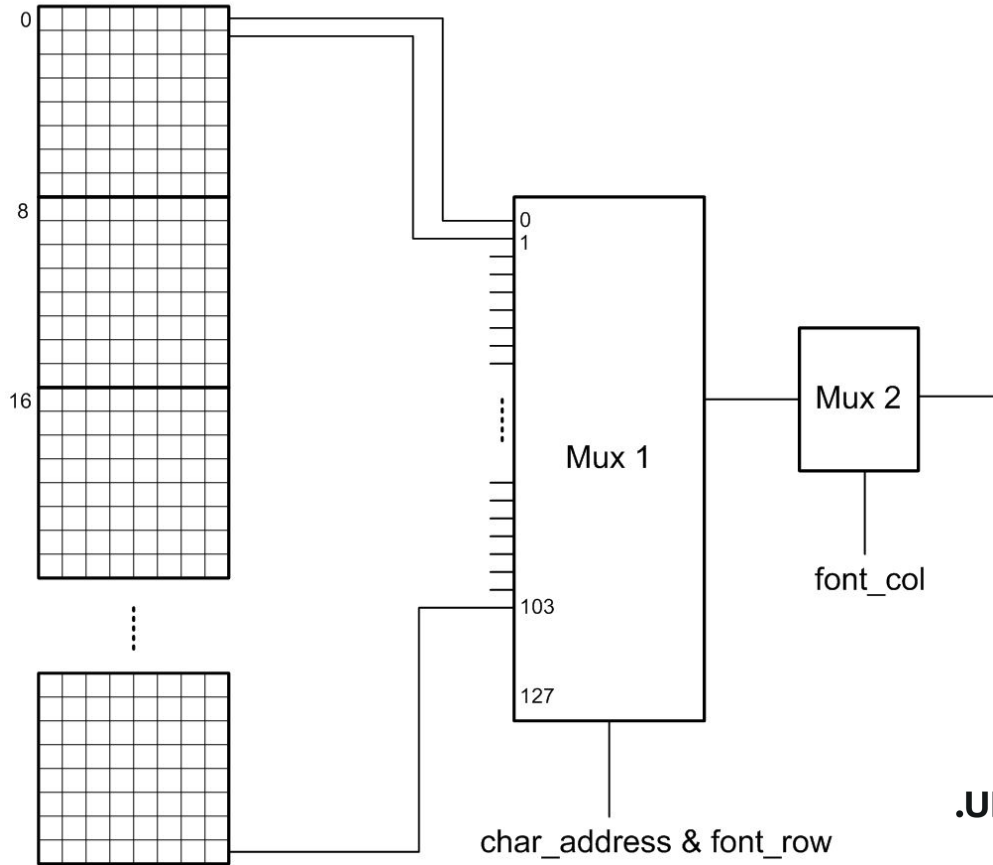

ROM

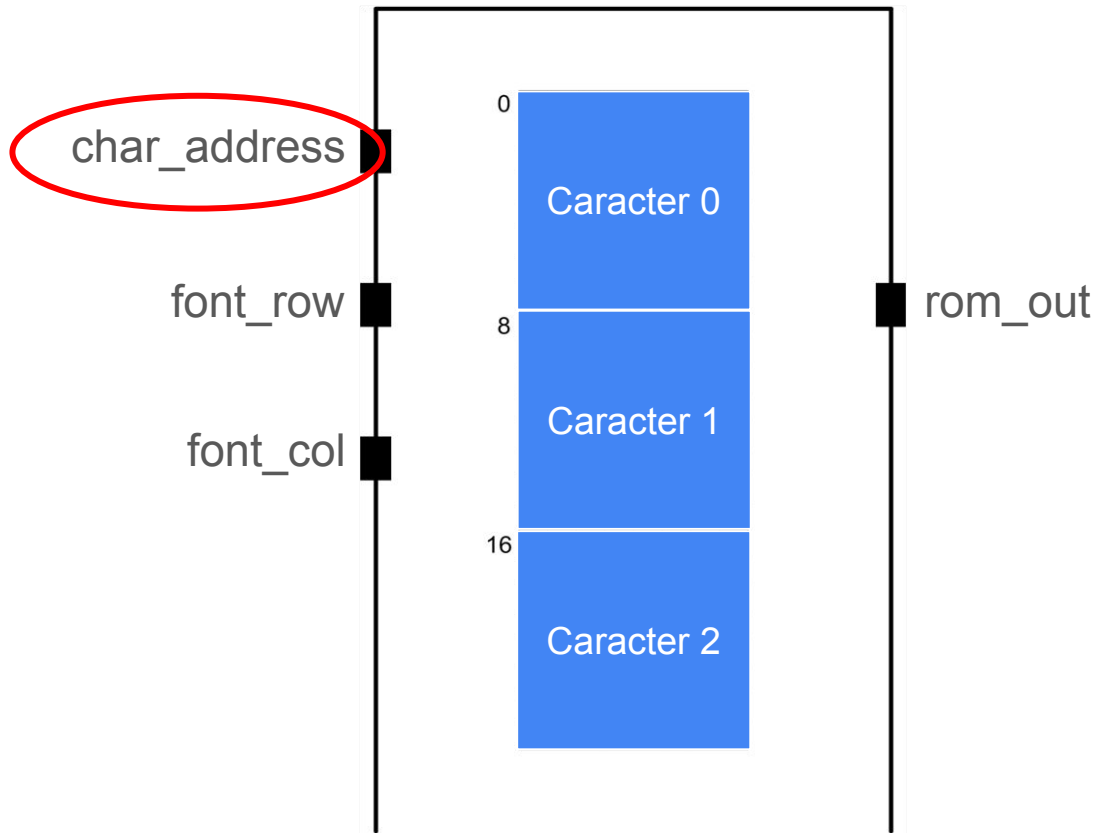

ROM

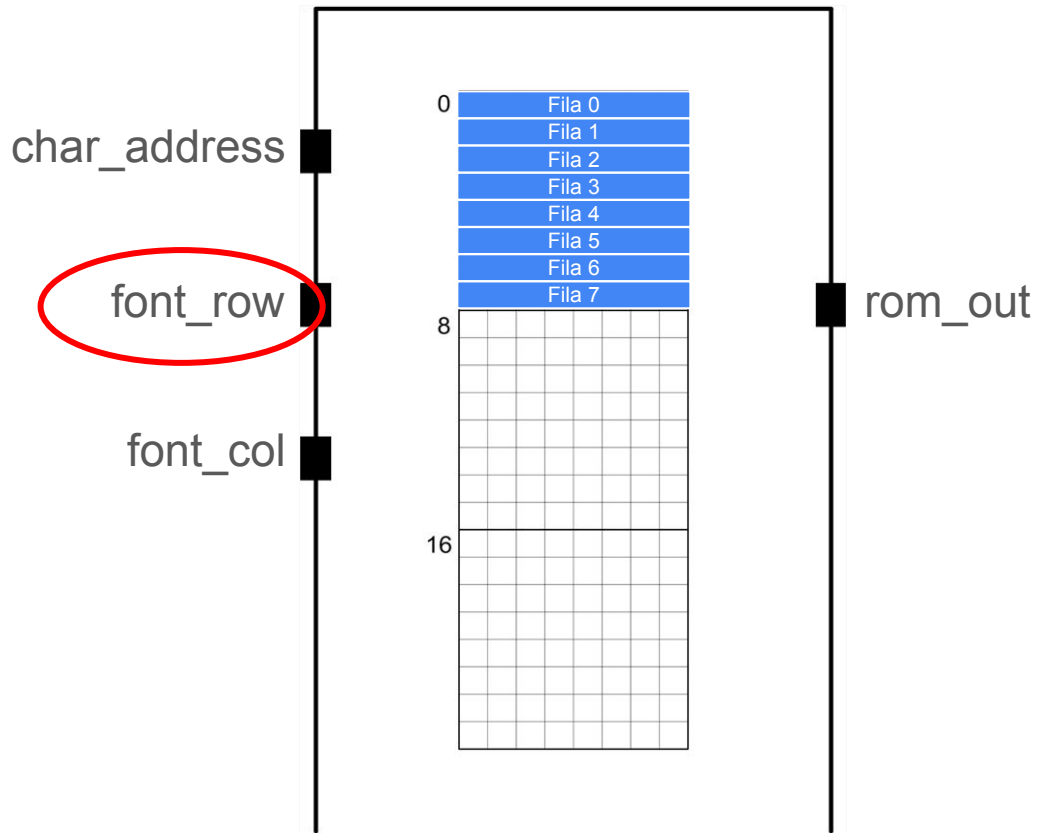

ROM

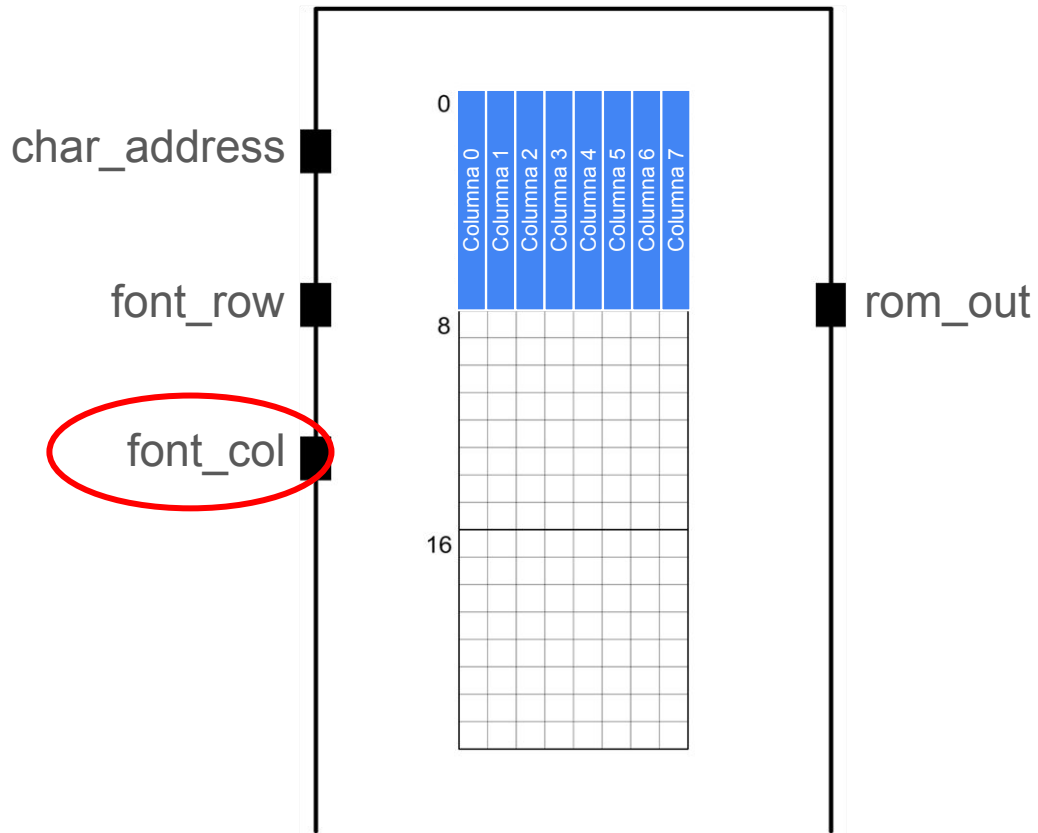

ROM

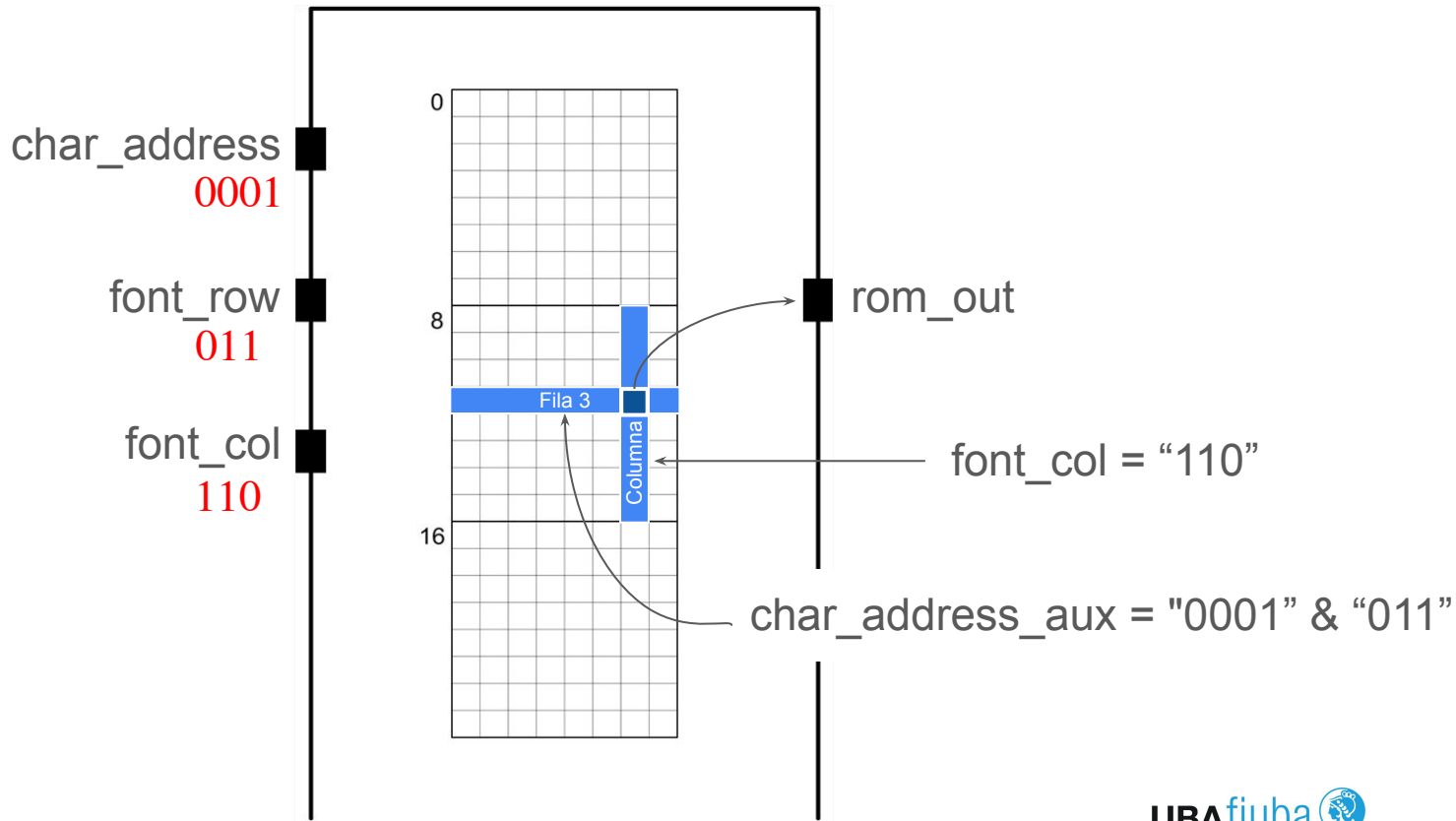

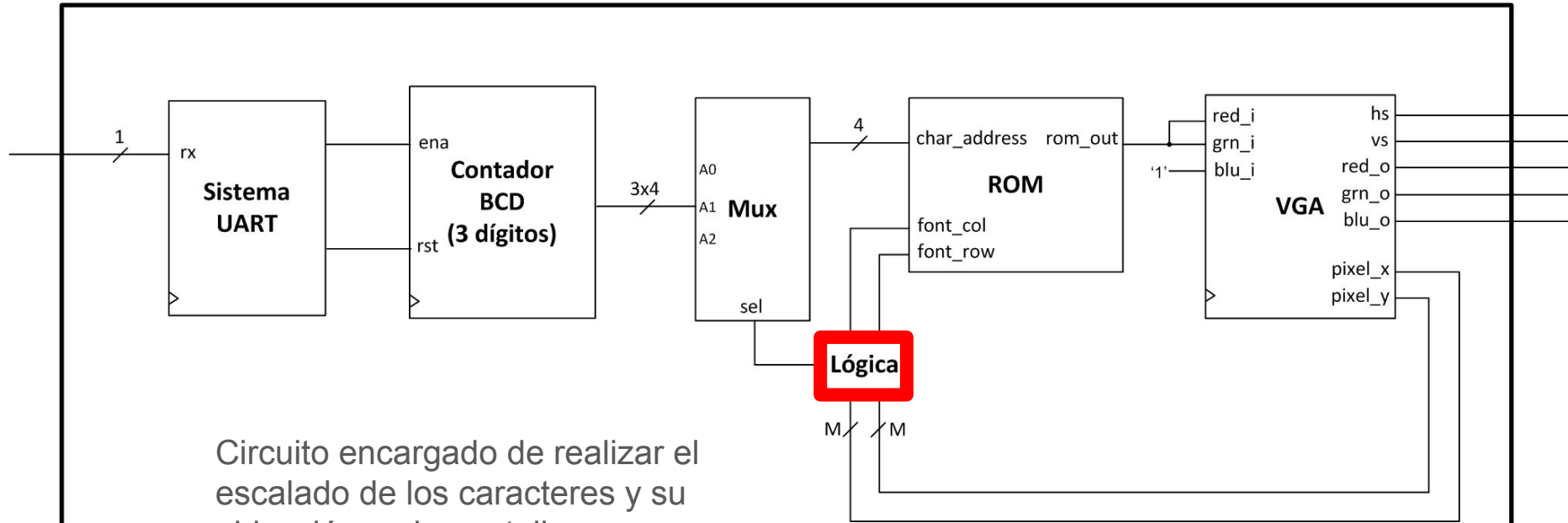

Circuito encargado de realizar el escalado de los caracteres y su ubicación en la pantalla

Lógica

Distribución de los caracteres en pantalla

